

Service Manual

THE FISHER®

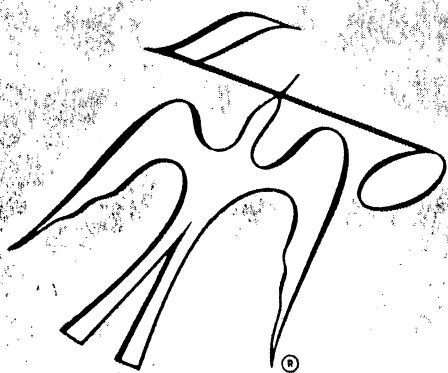

600-T

CHASSIS SERIAL NUMBERS
BEGINNING 37000

\$2.00

FISHER RADIO • LONG ISLAND CITY • NEW YORK 11101

CAUTION: This is a FISHER precision high-fidelity instrument. It should be serviced only by qualified personnel — trained in the repair of transistor equipment and printed circuitry.

EQUIPMENT AND TOOLS NEEDED

The following are needed to completely test and align modern high-fidelity instruments such as amplifiers, tuners and receivers.

Test Instruments

Vacuum-Tube Volt ohmmeter DC VTVM
Audio (AC) Vacuum-Tube Voltmeter (AC VTVM)
Oscilloscope (Flat to 100 kc minimum)
Audio (Sine-wave) Generator
Intermodulation Analyzer
Sweep (FM) Generator (88 to 108 mc)
Marker Generator
Multiplex Generator (preferably with RF output — FISHER Model 300 or equal).

Miscellaneous

Adjustable-Line-Voltage Transformer or line-voltage regulator
Load Resistors (2) — 8-ohm, 50-watt (or higher)
Stereo source (Turntable with stereo cartridge or Tape Deck)
Speakers (2) Full-range, for listening tests
Soldering iron (with small-diameter tip). Fully insulated from power line.

PRECAUTIONS

Many of the items below are included just as a reminder — they are normal procedures for experienced technicians. Shortcuts can be taken but often they cause additional damage — to transistors, circuit components or the printed-circuit board.

Soldering—A well-tinned, hot, clean soldering iron tip will make it easier to solder without damage to the printed-circuit board or the many many circuit components mounted on it. It is not the wattage of the iron that counts — it is the heat available at the tip. Low-wattage soldering irons will often take too long to heat a connection — pigtail leads will get too hot and damage the part. Too much heat, applied too long, will damage the printed-circuit board. Some 50-watt irons reach temperatures of 1,000° F — others will hardly melt solder. Small-diameter tips should be used for single solder connections — larger pyramid and chisel tips are needed for larger areas.

- When removing defective resistors, capacitors, etc., the leads should be cut as close to the body of the circuit component as possible. (If the part is not being returned for in-warranty factory replacement it may be cut in half — with diagonal-cutting pliers — to make removal easier.)
- Special de-soldering tippers are made for unsoldering multiple-terminal units like IF transformers and electrolytic capacitors. By unsoldering all terminals at the same time the part can be removed with little chance of breaking the printed-circuit board.
- Always disconnect the chassis from the power line when soldering. Turning the power switch OFF is not enough. Power-line leakage paths, through the heating element, can destroy transistors.

Transistors—Never attempt to do any work on the transistor amplifiers without first disconnecting the AC-power linecord — wait until the power supply filter-capacitors have discharged.

- Guard against shorts — it takes only an instant for a base-to-collector short to destroy that transistor and possibly others direct-coupled to it. [In the time it takes for a dropped machine screw, washer or even the screwdriver, to glance off a pair of socket terminals (or between a terminal and the chassis) a transistor can be ruined.]
- DO NOT bias the base of any transistor to, or near, the same voltage applied to its collector.
- DO NOT use an ohmmeter for testing transistors. The voltage applied through the test probes may be higher than the base-emitter breakdown voltage of the transistor.

Output Stage and Driver—Replacements for output and driver transistors, if necessary, must be made from the same beta group as the original type. The beta group is indicated by a colored dot on the mounting flange of the transistor. Be sure to include this information, when ordering replacement transistors.

- If one output transistor burns out (open or shorts), always remove all output transistors in that channel and check the bias adjustment, the control and other parts in the network with an ohmmeter before inserting a new transistor. All output transistors in one channel will be destroyed if the base-biasing circuit is open on the emitter end.

- When mounting a replacement power transistor be sure the bottom of the flange, the mica insulator and the surface of the heat sink are free of foreign matter. Dust and grit can prevent perfect contact. This reduces heat transfer to the heat sink. Metallic particles can puncture the insulator and cause shorts — ruining the transistor.

- Silicone grease must be used between the transistor and the mica insulator and between the mica and the heat sink for best heat conduction. Heat is the greatest enemy of electronic equipment. It can shorten the life of transistors, capacitors and resistors. (Use Dow-Corning DC-3 or C20194 or equivalent compounds made for power transistor heat conduction.)

- Use care when making connections to speakers and output terminals. Any frayed wire ends can cause shorts that may burn out the output transistors — they are direct-coupled to the speakers. There is no output transformer — nothing to limit current through the transistors except the fuses. To reduce the possibility of shorts at the speakers, lugs should be used on the exposed ends — at least the ends of the stranded wires should be tinned to prevent frayed wire ends. The current in the speakers and output circuitry is quite high. Any poor contact or small-size wire, can cause power losses in the speaker system. Use 14 or 16 AWG for long runs of speaker-connecting wiring.

DC-Voltage Measurements—These basic tests of the transistor circuitry are made without the signal generator. Without any signal input measure the circuit voltages — as indicated on the schematic. The voltage difference between the base and the emitter should be in the millivolt range — a sensitive DC meter is needed for these readings. A low-voltage range of 1 volt, full scale — or lower — is needed.

Audio-Voltage (gain) Measurements—The schematic and printed-circuit board layout diagrams are used. Input signals are injected at the proper points — found most quickly by using layout of the printed-circuit board instead of the schematic. An AUDIO (AC) VTVM connected to the test points should indicate voltages close to those values shown in the boxes on the schematic. Many of the signal levels in the input stages are only a few millivolts — they can not be read on the AC ranges supplied on most Vacuum-Tube AC/DC Volt-ohmmeters (VTVMs). Even with a 1-volt range a signal level of 100 millivolts (.1 volt) will be the first 1/10 of the meter scale. A reading of 1 millivolt (.001 volt) will hardly even move the meter needle.

1240 PREAMPLIFIER • SCHEMATIC

- NOTE -
SE4010 MAY BE
SUBSTITUTED FOR
A1380 (Q101, Q102).

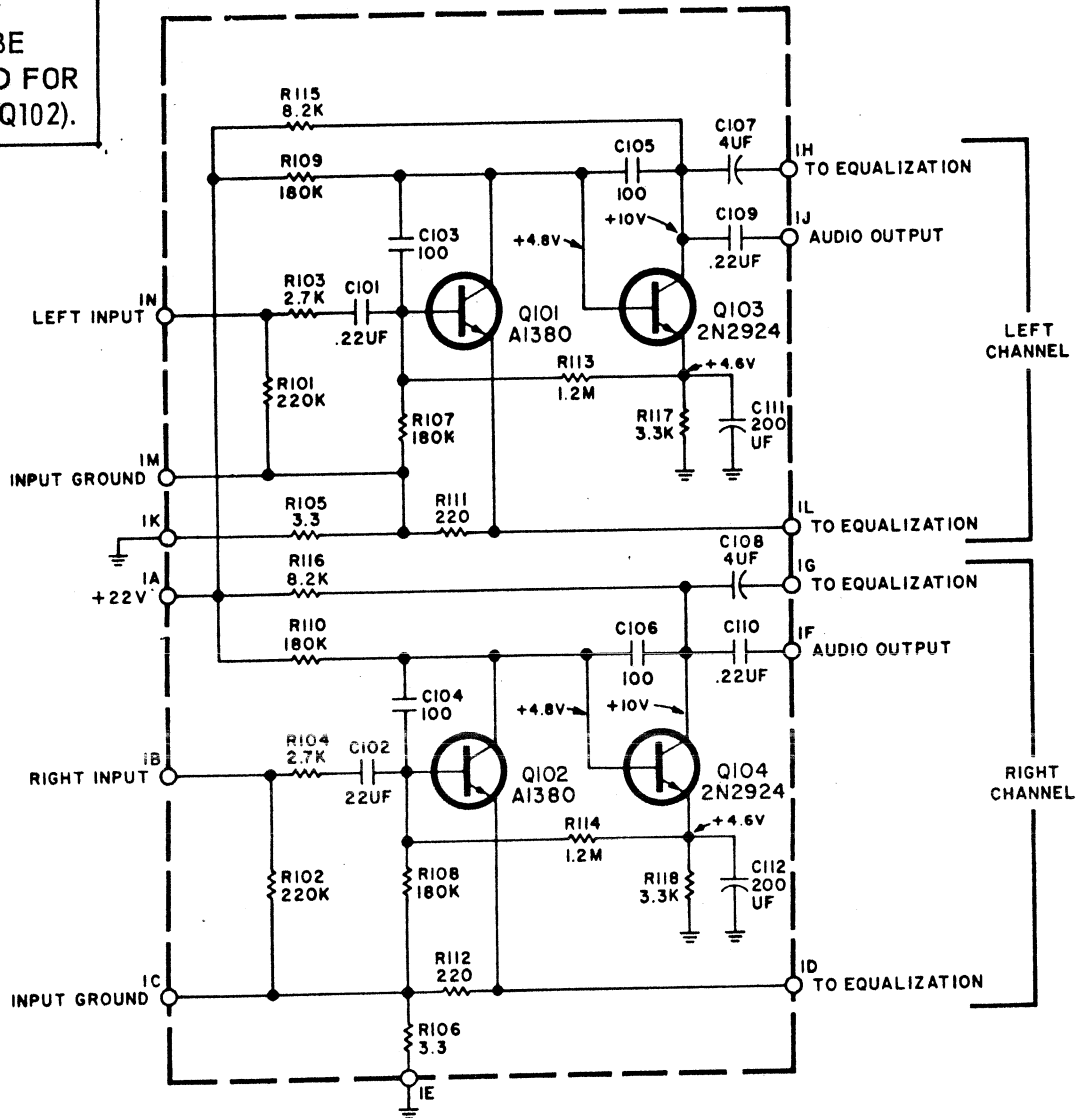

AW # 2293 A

POWER OUTPUT MEASUREMENT

The power-output stage of this unit is designed to deliver its full-rated power with program material (voice or music) into 4-to-16-ohm loads for indefinite periods.

When a constant audio tone is used as a signal to measure the *continuous RMS power output* certain precautions must be taken.

- Measure the power output of one channel at a time.
- Limit the measurement period to 10 minutes (with a load resistance between 4 and 16 ohms).

Should it ever be necessary to measure the power output of *both channels simultaneously*, use a load of 4 or 8 ohms (per channel), limit measurement to a period *not longer than 1 minute* for a 4-ohm load or to 5 minutes for an 8-ohm load.

PREAMPLIFIER • PRINTED CIRCUIT LAYOUT

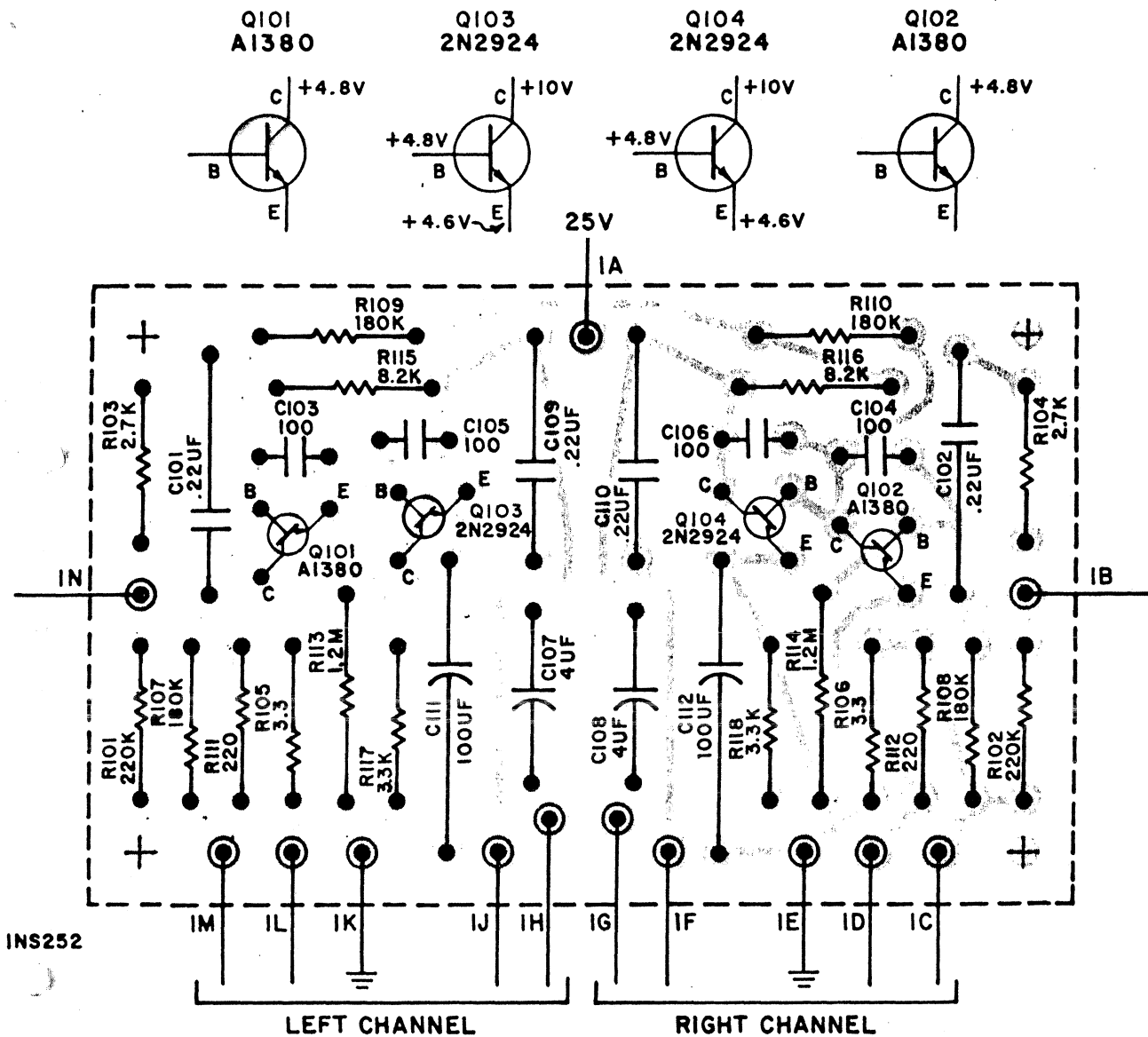

PARTS DESCRIPTION LIST

Symbol	Description	Part No.	Symbol	Description	Part No.
R101	Resistor, 220K	R12DC224J	C101	Capacitor, .22UF/160V	C50B575-3
R102	Resistor, 220K	R12DC224J	C102	Capacitor, .22UF/160V	C50B575-3
R103	Resistor, 2.7K	R12DC272J	C103	Capacitor, 100/±10%	C50B568-3
R104	Resistor, 2.7K	R12DC272J	C104	Capacitor, 100/±10%	C50B568-3
R105	Resistor, 3.3	R12DC3R3J	C105	Capacitor, 100/±10%	C50B568-3
R106	Resistor, 3.3	R12DC3R3J	C106	Capacitor, 100/±10%	C50B568-3
R107	Resistor, 180K	R12DC184J	C107	Capacitor, 4UF/35V	C50483-1
R108	Resistor, 180K	R12DC184J	C108	Capacitor, 4UF/35V	C50483-1
R109	Resistor, 180K	R12DC184J	C109	Capacitor, .22UF/160V	C50575-3
R110	Resistor, 180K	R12DC184J	C110	Capacitor, .22UF/160V	C50575-3
R111	Resistor, 220	R12DC221J	C111	Capacitor, 100UF/15V	C50483-5
R112	Resistor, 220	R12DC221J	C112	Capacitor, 100UF/15V	C50483-5
R113	Resistor, 1.2M	R33DC125J	Q101	Transistor	A1380
R114	Resistor, 1.2M	R33DC125J	Q102	Transistor	A1380
R115	Resistor, 8.2K	R12DC822J	Q103	Transistor	2N2924
R116	Resistor, 8.2K	R12DC822J	Q104	Transistor	2N2924
R117	Resistor, 3.3K	R12DC332J	—	Transistor Spacer	E50A624
R118	Resistor, 3.3K	R12DC332J	—	Printed Circuit Board	PB1240

1-2/A FS-1254-H

283

INS 282

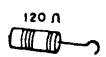

1249 MULTIPLEX MODIFICATION (for early production runs).

In some reception areas the possibility of an audible interference exists when a stereophonic station simultaneously transmitting an SCA (background music) signal is received.

To fully eliminate this possibility in the aforementioned models, a change in the existing SCA filter circuits on the Multiplex-Decoder Printed Circuit Board (P-1249) should be made, as outlined below.

Fisher Radio has prepared a package (Part No. SCA) of the few small parts required for this change, which can be performed easily by a service station or a dealer. Alignment is not required.

Refer to the photograph of the MPX adaptor board. The parts to be changed are indicated. Please note that some previous parts differ in value

- | | |
|--|--|
| <p>Radd 22k
This is an addition</p> <p>R405 was 39k or 56k
Must be 39k</p> <p>R412 was 6.8k or 8.2k
Must be 15k paralleled
with 120pf (Cadd)</p> | <p>C406 was 56pf or 82pf
Must be 15pf</p> <p>C410 was 820pf
Must be 220 pf</p> <p>Cadd 120pf parallel
with 15k (R412)
120 pf is an addition</p> <p>L401 was 5.3mh
Must be 20mh</p> |
|--|--|

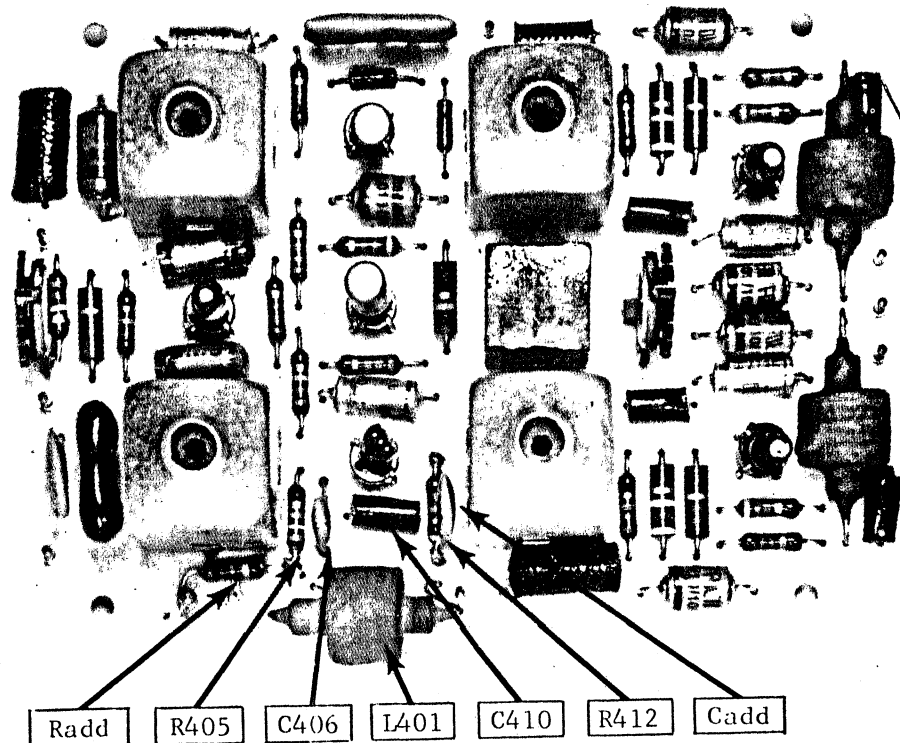

1249 MULTIPLEX DECODER • PRODUCTION CHANGES

Reducing hum in the FM AUTOMATIC position of the SELECTOR switch

The SCA-filter coil on the 1249 Multiplex Decoder board may pick up hum from the power transformer. The position of the coil on the printed-circuit board is critical and the coil might be displaced during shipping. To eliminate the need for critical positioning the following change has been made:

- Mount a 3-terminal strip (FISHER part number E-100T3N) on the chassis, parallel to the short side of the front-end assembly, using the existing hexhead screw.
- Remove the SCA-filter coil from the MPX printed-circuit board. (Just clip the pig-tail leads of the SCA-filter coil $\frac{1}{4}$ -inch from the MPX board.)
- Connect a twisted pair of insulated wires from the original coil terminals on the MPX printed-circuit board to the two insulated terminals of the added terminal strip. (Dress the wires as shown in the photograph.)
- Solder the pig-tail leads of the SCA-filter coil to the two insulated terminals of the added terminal strip along with the ends of the twisted pair of wires connecting it to the MPX printed-circuit board.
- Solder the twisted pair of insulated wires to the $\frac{1}{4}$ -inch long leads left when the SCA-filter coil was clipped off of the MPX printed-circuit board.
- Set the SELECTOR switch to FM AUTOMATIC; tune to a point between FM-broadcast stations; push MUTING switch ON and position the SCA-filter coil for minimum hum with VOLUME turned up.

1249 Multiplex Decoder Board

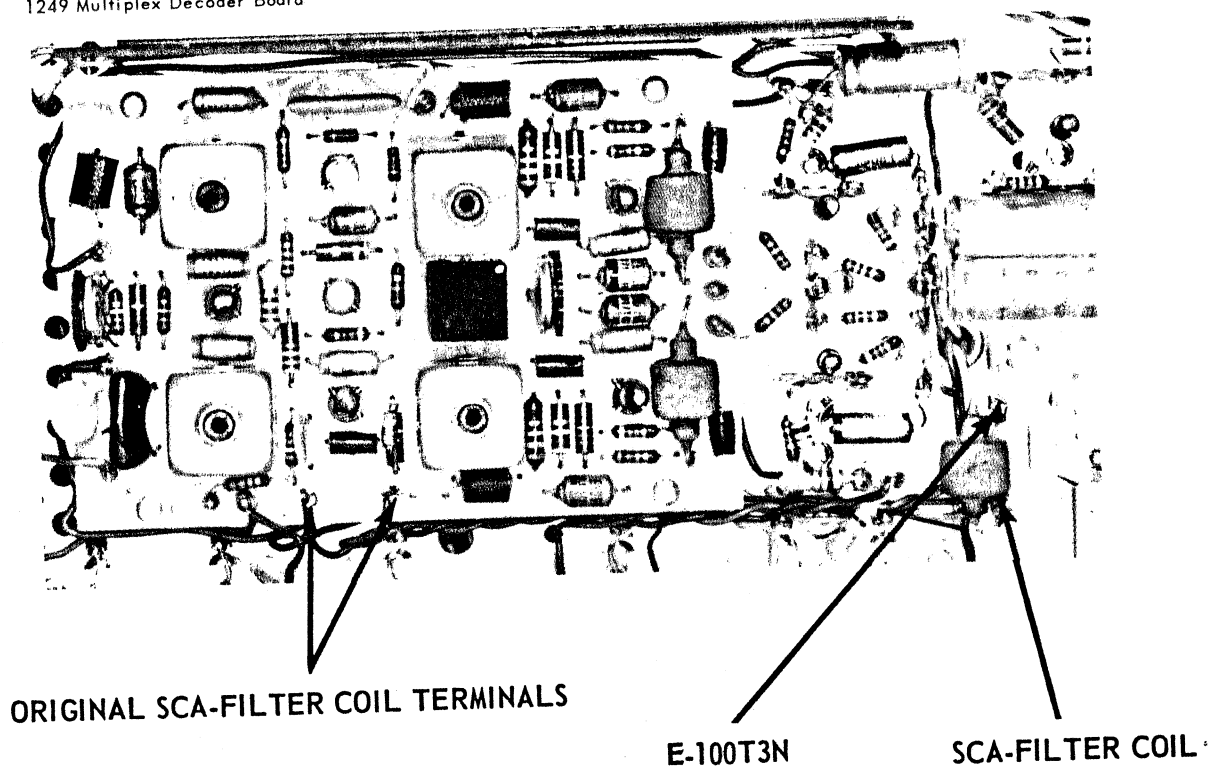

966-2 F M FRONT END • SCHEMATIC

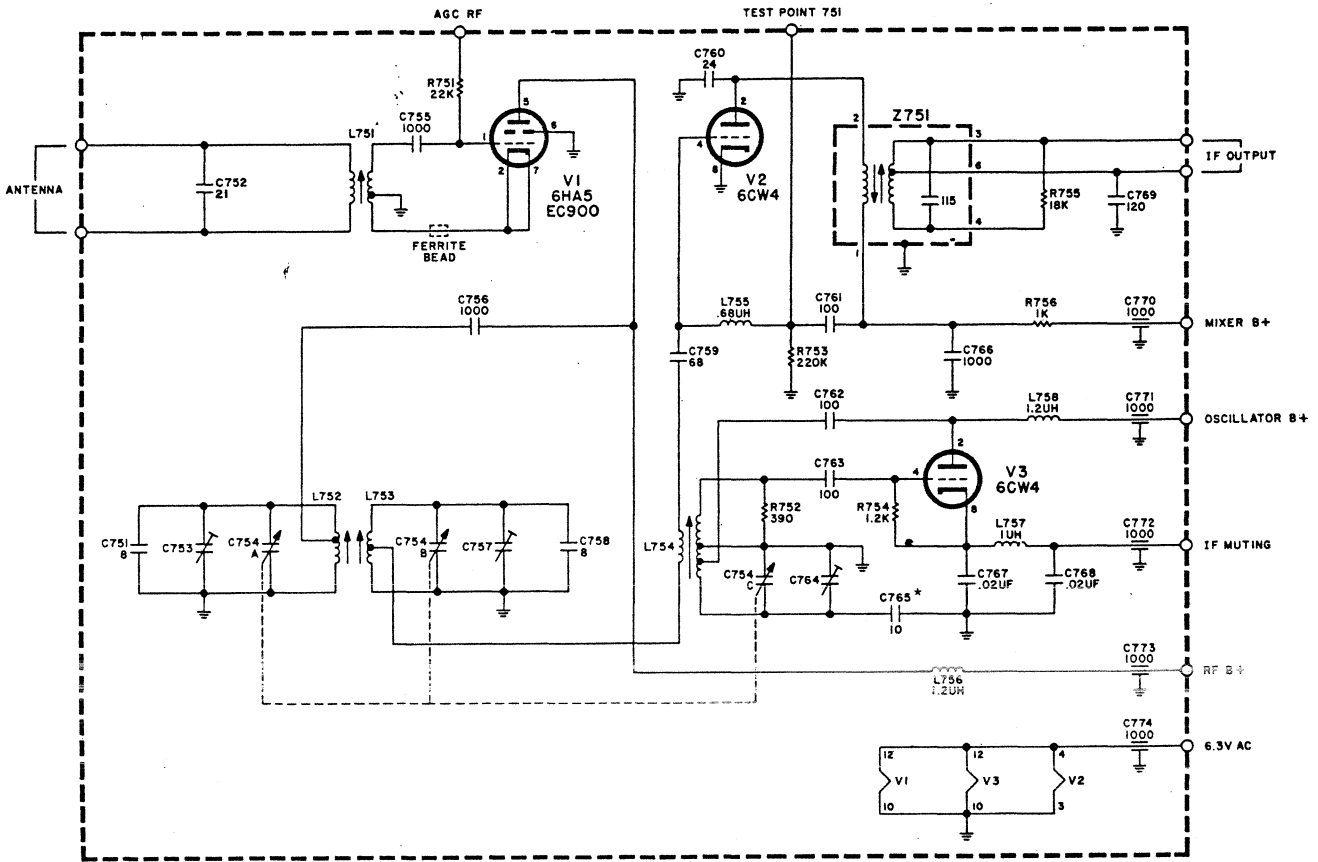

PARTS DESCRIPTION LIST

CAPACITORS

10% tolerance for all fixed capacitors, unless otherwise noted or marked GMV (guaranteed minimum value). All capacitors not marked uF are pF (uµF).

Symbol	Description	Part No.
C751	Ceramic, 8, 5%, NPO, 1000V	C50070-45
C752	Ceramic, 21, 5%, N750, 1000V	C50070-32
C753	Trimmer	C662-123
C754A,B,C	Variable, Tuning	C966C117-1
C755, 756	Ceramic, 1000, GMV, 500V	C50089-2
C757	Trimmer	C662-123
C758	Ceramic, 8, 5%, NPO, 1000V	C50070-45
C759	Ceramic, 68, 5%, N750, 1000V	C50070-35
C760	Ceramic, 24, 5%, N150, 1000V	C50070-8
C761	Ceramic, 100, 5%, N1500, 1000V	C50070-19
C762, 763	Ceramic, 100, N1500, 1000V	C50070-6
C764	Trimmer	C662-123
C765	Ceramic, 10, ±.5pF, P100, 500V	CC20AJ100D5
C766	Ceramic, 1000, 1000V	C50072-3
C767, 768	Ceramic, .02uF, +80-20%, 100V	C50095-1
C769	Ceramic, 120, N1500, 1000V	C50070-9
C770, 771, 772, 773, 774	Ceramic, Feedthru, 1000, GMV	C592-187

RESISTORS

Deposited Carbon, in ohms, 5% tolerance, 1/8 watt. K=Kilohms, M=Megohms.

Symbol	Description	Part No.
R751	22K	R12DC223J
R752	390	R12DC391J
R753	220K	R12DC224J
R754	1.2K	R12DC122J
R755	18K	R12DC183J
R756	1K	R12DC102J

MISCELLANEOUS

Symbol	Description	Part No.
L751	Coil, Antenna	L966-113
L752	Coil, RF	L1034-113
L753	Coil, Mixer	L966-115
L754	Coil, Oscillator	A5966-107
L755	Choke, .68 Microhenry	L50066-1
L756	Choke, 1.2 Microhenry	L50066-3
L757	Choke, 1 Microhenry	L50066-2
L758	Choke, 1.2 Microhenry	L50066-3
V751	Tube, EC900/6HA5	V-EC900
V752, 753	Nuvistor, 6CW4	V-6CW4
Z751	Transformer, IF	ZZ50210-45

* To prevent oscillator drift, under unusual or extreme conditions, replace temperature-compensating capacitor C765 with FISHER part number CC20CG100D5 (Ceramic, 10pF, ±0.5pF, NPO, 500V).

TROUBLESHOOTING GUIDE

Does not go on – (meter and dial lamps do not light). – In any position of SELECTOR

- Check:
- Fuse F1
 - AC-interlock switch S3 (chassis will not operate with cover removed).
 - Power cord, plug and wall outlet (use test lamp in rear chassis outlets).
 - AC ON-OFF switch S4 (part of VOLUME control).

Hum – (both channels) – in any position of SELECTOR

- Check:
- Remove all plugs from rear chassis jacks (especially any in RCRDR jacks).
 - DC power supply – CR1, CR2, CR3, CR4; C25, C26; C24, C27, Q11.

Hum – in FM positions of SELECTOR only.

- Check:
- Tune to other broadcast stations.
 - CR5, C2A, C2B, R2.
 - Multiplex decoder production changes in this manual.
- Test:
- V1, V2, V3 for filament leakage.

Distorted, weak or No audio output. – (both channels) – in any position of SELECTOR.

- Check:
- Set speaker selector to MAIN + REMOTE position
 - Set MONITOR switch to OFF (out) position.
 - Speaker connections
 - Jumpers between REV IN and REV OUT jacks.
 - Speaker IMPEDANCE SELECTOR switch.
- Test:
- Voltages at: CR1, CR3, C25, R45; CR2, CR4, CR26, R51, R53; C23, R44, R45; C22, R44; C27, R30, R51, Q11; Q12, R17, C10.

Distorted, Weak or No audio output – (LEFT channel only) – in any position of SELECTOR.

- Check:
- Set BALANCE control to center or "0" (zero) position.
 - Speaker connections.
 - Jumper between LEFT REV IN and REV OUT jacks.
 - Speaker IMPEDANCE SELECTOR switch.
 - Fuses F2, F3.
 - Q5, Q6, Q7, Q8, Q9.
 - Setting of bias adjustments P1 (R81), P2 (R91).
 - 1096 Audio Control Amplifier section and PC3.
 - R31 and C17.

Distorted, Weak or No audio output – (RIGHT channel only) in any position of SELECTOR.

- Check:
- Set BALANCE control to center of "0" position.
 - Speaker connections.
 - Jumper between RIGHT REV IN and REV OUT jacks.
 - Speaker IMPEDANCE SELECTOR switch.
 - Fuses F4, F5.
 - Q1, Q2, Q3, Q4, Q10.
 - Setting of Bias adjustments (P3 (R92), P4 (R82)).
 - 1096 Audio Control Amplifier section and PC4.
 - R32 and C16.

Distorted, Weak or No audio output – (either channel) – PHONO and TAPE HEAD positions of SELECTOR only.

- Check:
- Interchange input cables in rear-chassis PHONO and TAPE HEAD jacks temporarily.
 - 1240 Preamp section.

CHASSIS LAYOUT

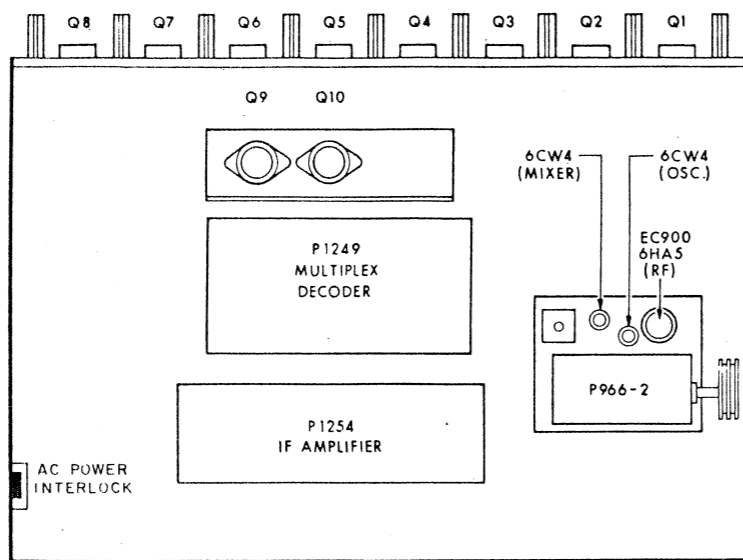

INS247A

TOP VIEW

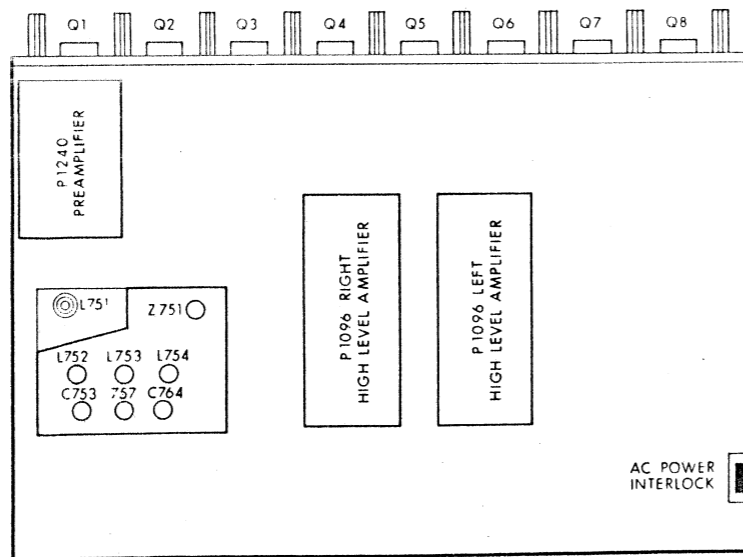

INS 248A

BOTTOM VIEW

COMPONENT CONNECTIONS

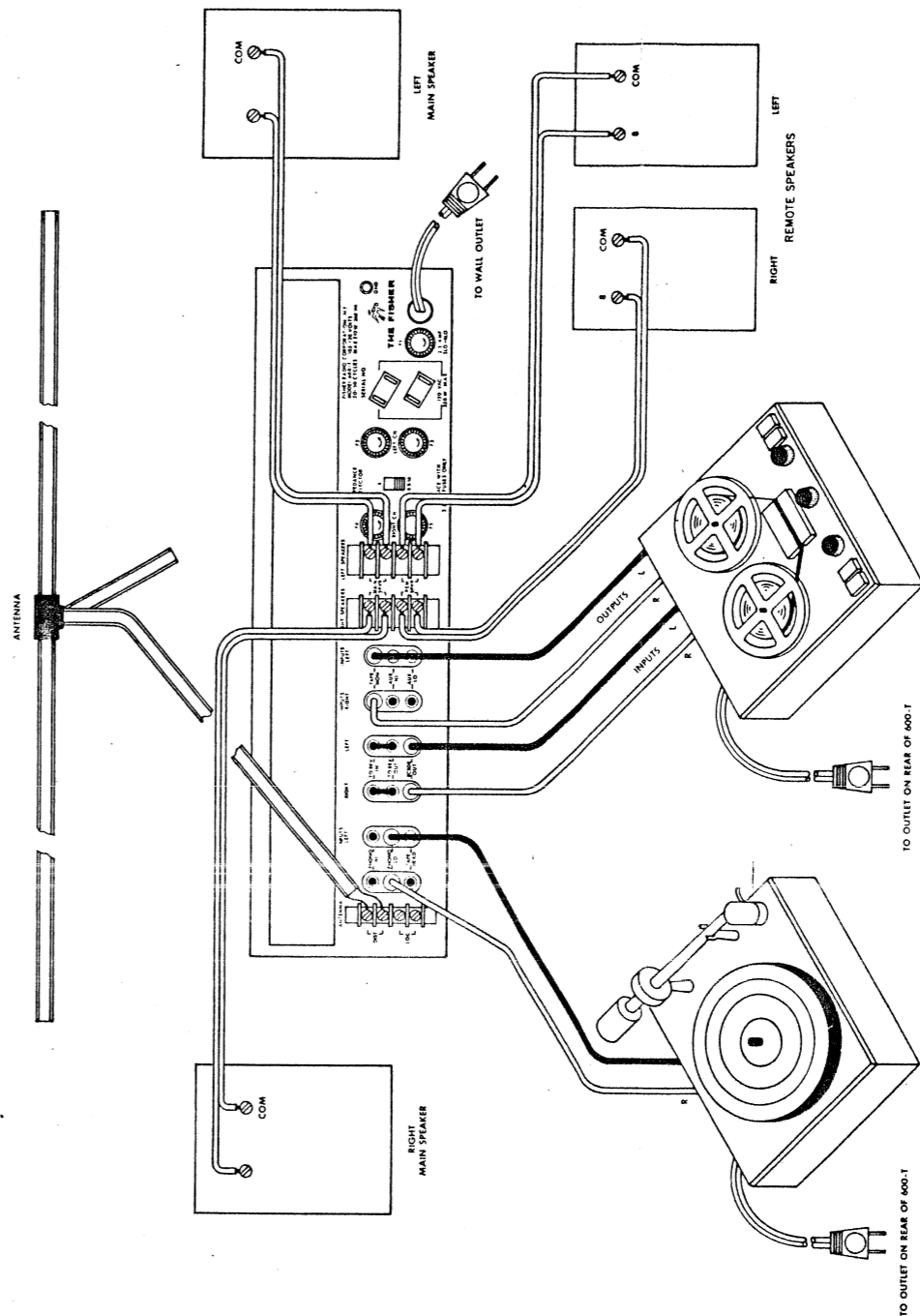

INS 212

(L-9) PS-916-0-11



FISHER RADIO CORPORATION • NEW YORK

N946-1038X

© COPYRIGHT 1965 FISHER RADIO CORPORATION All Rights Reserved

PRINTED U.S.A.

704

PLEX DECODER • SCHEMATIC

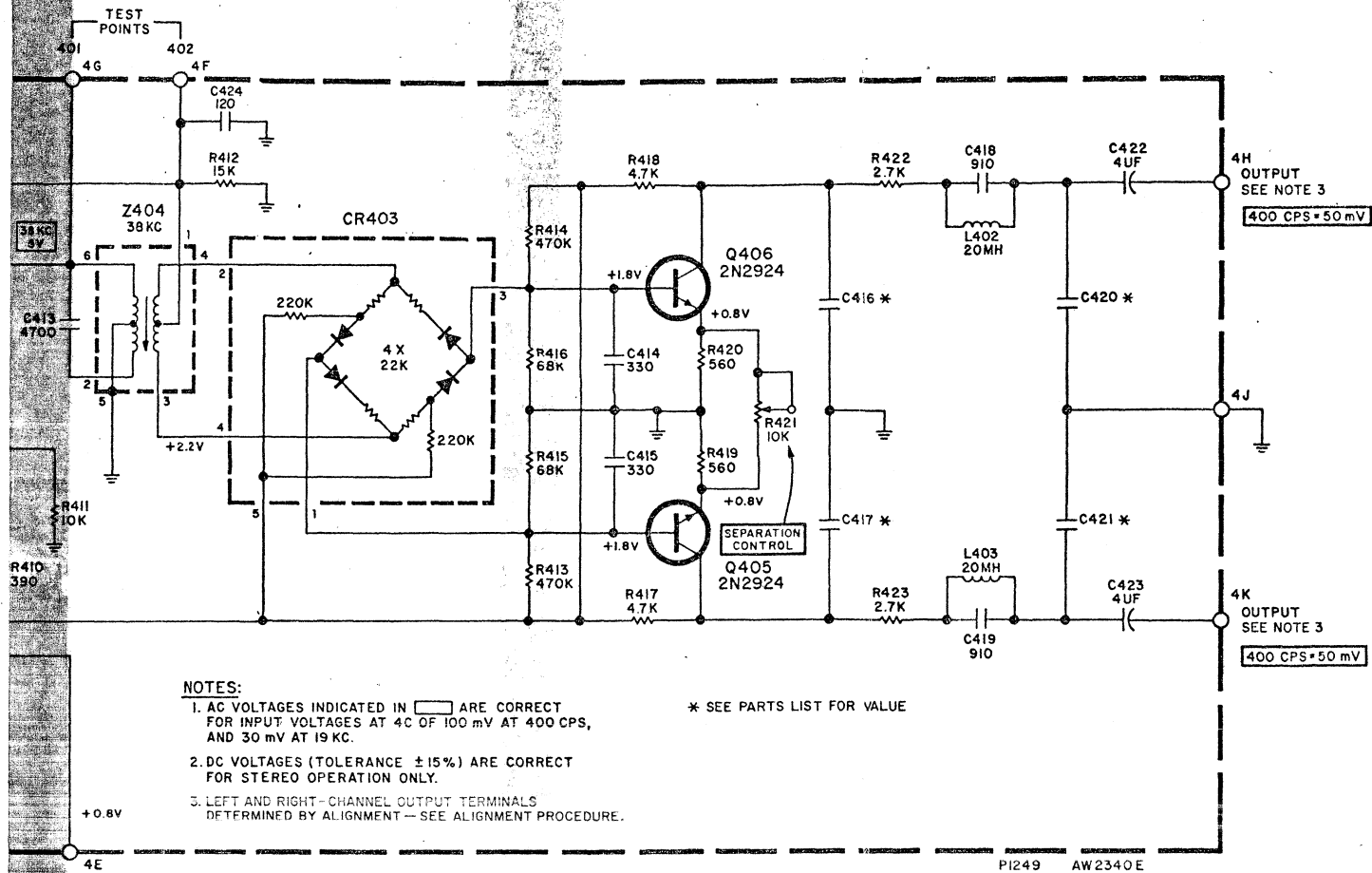

NOTES:
 1. AC VOLTAGES INDICATED IN ARE CORRECT FOR INPUT VOLTAGES AT 4C OF 100 mV AT 400 CPS, AND 30 mV AT 19 KC.
 2. DC VOLTAGES (TOLERANCE ± 15%) ARE CORRECT FOR STEREO OPERATION ONLY.
 3. LEFT AND RIGHT-CHANNEL OUTPUT TERMINALS DETERMINED BY ALIGNMENT—SEE ALIGNMENT PROCEDURE.

* SEE PARTS LIST FOR VALUE

* FOR VALUE REFER TO PARTS LIST

LAST
R424/C424

PARTS DESCRIPTION LIST

C422, 423 Electrolytic, 4uF, 35V
 C424 Polystyrene, 120, 5%, 33V
 †Used on PB1249-1 Board—(Tube-type IF Amplifiers)
 *Used on PB1249-2 Board—(Transistor-type IF Amplifiers)
 **For export models only.

RESISTORS AND POTENTIOMETERS

Deposited Carbon, in ohms, 5% tolerance, 1/4-watt, unless otherwise noted. K=Kilohms, M=Megohms.

Symbol	Description	Part No.
R401	Pot., Trimmer, 100K, ±30%	R50150-66
R402	Composition, 1K, 10%, 1/2W	RC20BF102K
R403	270K	R12DC274J
R404	150	R12DC151J
R405	39K	R12DC393J
R406	1.2K	R12DC122J
R407	470	R12DC471J
R408	330K	R12DC334J
R409	33K	R12DC333J
R410	390	R12DC391J
R411	10K	R12DC103J
R412	15K	R12DC153J
R413, 414	470K	R12DC474J

R415, 416	68K
R417, 418	4.7K
R419, 420	560
R421	Pot., Trimmer, 10K, ±30%
R422, 423	2.7K
R424	22K

R12DC683J
R12DC472J
R12DC561J
R50150-63
R12DC272J
R12DC223J

MISCELLANEOUS

Symbol	Description	Part No.
CR401, 402	Diode, V1112	V1112
CR403	Ring Demodulator	V50260-29
L401	Coil, 20mH	L50334-2
L402, 403	Coil, 20mH	L50334-6
Q401	Transistor, 2N2924	TR2N2924-18
Q402, 403	Transistor, 2N2614	TR2N2614
Q404	Transistor, 11417	TR9100-18
Q405, 406	Transistor, 2N2924	TR2N2924-18
PC401	Printed Circuit	PC508187-21
Z401	Transformer, 19K.	ZZ50210-63
Z402	Transformer, 19Kc	ZZ50210-67
Z403	Transformer, 19Kc	ZZ50210-64
Z404	Transformer, 38Kc	ZZ50210-65

MAIN CHASSIS • PARTS DESCRIPTION LIST

CAPACITORS

10% tolerance for all fixed capacitors, unless otherwise noted or marked GMV (guaranteed minimum value). All capacitors not marked uF are pF (uF).

Symbol	Description	Part No.
C1	Ceramic, .02uF, +80 -20%, 100V	C50095-1
C2A, B, C	Electrolytic, 3 X 50uF, 200V	C50180-70
C3	Ceramic, .02uF, +80 -20%, 100V	C50095-1
C4	Electrolytic, 4uF, 35V	C50483-1
C5	Electrolytic, 200uF, 35V	C50483-7
C6, 7, 8	Ceramic, .02uF, +80 -20%, 100V	C50095-1
C9, 10	Electrolytic, 200uF, 35V	C50483-7
C11	Electrolytic, 100uF, 25V	C50483-6
C12, 13	Mylar, 0.1uF, 20%, 250V	C50B575-1
C14, 15	-Deleted-	- - -
C16, 17	Electrolytic, 200uF, 35V	C50483-7
C18, 19	Ceramic, 100, GMV, N1500, 1000V	C50070-5

RESISTORS AND POTENTIOMETERS

Deposited Carbon, in ohms, 5% tolerance, 1/8 watt unless otherwise noted:

Symbol	Description	Part No.
R1	Composition, 270, 10%, 1/2W	RC20BF271K
R2	Wirewound, 560, 5%, 2W	RW200W561J
R3	Composition, 1.8K, 10%, 1/2W	RC20BF182K
R4	Composition, 560, 10%, 1/2W	RC20BF561K
R5	Composition, 2.2K, 10%, 1/2W	RC20BF222K
R6	Composition, 6.8K, 10%, 2W	RC40BF682K
R7	1.5K	R12DC152J
R8	Composition, 15K, 10%, 1/2W	RC20BF153K
R9	Pot., 500K, Muting Level	R50B150-10
R10	56K	R12DC563J
R11	Composition, 560, 10%, 1/2W	RC20BF561K
R12	Composition, 47K, 10%, 1/2W	RC20BF473K
R13	Composition, 12K, 10%, 1/2W	RC20BF123K
R14	Composition, 150, 10%, 1/2W	RC20BF151K
R15	330	R12DC331J
R16	Composition, 390, 10%, 1/2W	RC20BF391K
R17	Composition, 560, 10%, 1/2W	RC20BF561K
R18	100K	R12DC104J
R19, 20	180K	R12DC184J
R21, 22	18K	R12DC183J
R23, 24	1K	R12DC102J
R25, 26	4.7K	R12DC472J
R27, 28	2.7K	R12DC272J
R29	1K	R12DC102J
R30	Composition, 8.2K, 10%, 1/2W	RC20BF822K
R31, 32	Composition, 1K, 10%, 1/2W	RC20BF102K
R33	-Deleted-	- - -
R34, 35	220K	R12DC224J
R36, 37	47K	R12DC473J
R38, 39	100K	R12DC104J
R40, 41	47K	R12DC473J
R42, 43	*Composition, 1.2M, 10%, 1/2W	RC20BF125K
R44	Composition, 1K, 10%, 1/2W	RC20BF102K
R45	Wirewound, 39, 5%, 2W	RW200W390J

C20, 21	Ceramic, 100, N1500, 1000V	C50070-6
C22	Electrolytic, 200uF, 35V	C50483-7
C23	Electrolytic, 1000uF, 50V	C50180-71
C24	Electrolytic, 500uF, 35V	C50483-7
C25, 26	Electrolytic, 3000uF, 40V	C50180-60
C27	Electrolytic, 500uF, 35V	C50483-17
C28	Molded, .01uF, 20%, 600V	C2747
C29, 30	Ceramic, 100, N1500, 1000V	C50070-6
C31, 32	Ceramic, 680, 1000V	C50072-2
C33, 34	Mylar, .33uF, 250V	C50B633-2
C35, 36	Electrolytic, 1000uF, 15V	C50283-10
C37, 38	Electrolytic, 200uF, 15V	C50483-13
C39, 40, 41, 42	Electrolytic, 100uF, 25V	C50483-6
C43, 44	Ceramic, 300, 1000V	C50072-39
C45, 46	Ceramic, 120, N1500, 1000V	C50070-9
C47, 48, 49, 50	Ceramic, 300, 1000V	C50072-39

R46, 47	47K	R12DC473J
R48	Composition, 120K, 10%, 1/2W	RC20BF124J
R49	Composition, 56, 10%, 1/2W	RC20BF560K
R50A, B	Pot., 100K, Dual, Treble	R50160-155
R51	Composition, 220, 10%, 1/2W	RC20BF221K
R52	Pot., 10, Light Dimmer	R50160-154-1
R53	Glass, 270, 5%, 7W	RP67W271J
R54	Wirewound, 1, 5%, 3W	RL300W010J
R55A, B	Pot., 100K, Dual, Bass	R50160-155
R56	Composition, 820K, 10%, 1/2W	RC20BF824K
R57, 58	1M	R12DC105J
R59, 60	560K	R12DC564J
R61, 62	56K	R12DC563J
R63, 64	2.7K	R12DC272J
R65A, B	Pot., 50K, Dual, Volume	R50160-151
R66, 67	1.8K	R12DC182J
R68A, B	Pot., 50K, Dual, Balance	R50160-157
R69, 70	Wirewound, 390, 5%, 2W	RW200W391J
R71, 72	150	R12DC151J
R73, 74	Wirewound, 330, 5%, 2W	RW200W331J
R75, 76	Wirewound, 270, 5%, 2W	RW200W271J
R77, 78	Wirewound, 100, 5%, 2W	RW200W101J
R79, 80	Wirewound, 220, 5%, 2W	RW200W221J
R81, 82	Pot., 10, DC Balance	R50160-142-1
R83, 84	Wirewound, 330, 5%, 2W	RW200W331J
R85, 86	Wirewound, 270, 5%, 2W	RW200W271J
R87, 88	Wirewound, 100, 5%, 2W	RW200W101J
R89, 90	Wirewound, 220, 5%, 2W	RW200W221J
R91, 92	Pot., 10, DC Balance	R50160-142-1
R93, 94, 95, 96	Composition, 22, 10%, 1/2W	RC20BF220K
R99, 100	Wirewound, 1, 5%, 3W	RL300W010J
R101, 102	Wirewound, 330, 5%, 2W	RW200W331J
R103A, B	Wirewound, Dual, 2.7 + 2.7, 10%, 10W	R50500-5
R104	-Deleted-	- - -
R105, 106	2.7K	R12DC272J
R107, 108	Wirewound, 220, 5%, 2W	RW200W221J
R109, 110	8.2K	R12DC822J

CONTROLS

Symbol	Description	Part No.			
R9	Pot., 500K, Muting Level	R50150-10	S1	Switch, Selector, Input	S946-235
R52	Pot., 10, Light Dimmer	R50160-154-1	S2	Switch, Speakers	S946-216
R50A, B	Pot., 100K, Dual Treble	R50160-155	S3	Switch, Interlock	S946B176
R55A, B	Pot., 100K, Dual, Bass	R50160-155	S4	Switch, Power (On Volume Control)	Part of R65A, B
R65A, B	Pot., 50K, Dual, Volume	R50160-151	S5A, B	Switch, Impedance Selector	S50200-2
R68A, B	Pot., 50K, Dual, Balance	R50160-157	PS1	Switch, PB, Low	
R81, 82	Pot., 10, DC Balance	R50160-142-1		Filter, Monitor, Volume	S946-226
R91, 92	Pot., 10, DC Balance	R50160-142-1	PS2	Switch, PB, Loudness, Muting, High Filter	S946-225

MISCELLANEOUS

Symbol	Description	Part No.			
CR1, 2, 3, 4	Diode, Silicon Rectifier	SR50517	--	Knob, Balance	E50561
CR5	Diode, Selenium Rectifier	SR50253-2	--	Knob, Volume	E50562-1
F1	Fuse, 2.5 Amp, Slo-Bio	F1077-118	--	Knob, Dual, Top, Tone Control	E50563
F2, 3, 4, 5	Fuse, 2 Amp	F755-145	--	Knob, Dual, Bottom, Tone Control	E50564
I1	Lamp, Stereo Beacon	I50594-1	--	Knob, Speaker Selector	E50565-1
I2	Lamp, Pointer, Part of Assembly	A550451-2	--	Knob, Tuning	E50565-2
I3, 4	Lamp, Dial	I50441-2	--	Screws, For Cage & Bottom Cover	H50598-7
L1	Choke, 2.2 Microhenry	L50066-6	--	Drive Wheel, Tuning Capacitor	H50588
L2, 3	Choke, 1 Microhenry	L50066-2	--	Barrier Strip, Antenna	E50596
PC1, 2	Printed Circuit, Equalization	PC50187-14	--	Barrier Strip, Speaker	E50170-4
PC3, 4	Printed Circuit, Tone	PC50489	--	Stereo Beacon Assembly	AS946B237
Q1 thru 10	Transistor, 35144	TR35144	--	Insulator, Transistor Socket	E50510
Q11	Transistor, 2614	TR2N2614	--	Socket, Transistor	X50509
Q12	Transistor, 2N2924-18	TR2N2924-18	--	Jack, Phone	J50545
Q13, 14	Transistor, 2924	TR2N2924	--	Nameplate Assembly, Dress Panel	AS946-228
T1	Transformer, Power	T946-239	--	Dial Glass, Screened	N946-203
T2	Transformer, Driver, Left Channel	T946-218-1	--	Meter, Tuning Indicator	M946-213
T3	Transformer, Driver, Right Channel	T946-218-2	--	Printed-Circuit Board, IF	PB1254
--	Insert, Dress Panel, Screened (Upper)	AS946-201	--	Printed-Circuit Board, MPX	PB1249-3
--	Insert, Dress Panel, Screened (Lower)	AS946-202	--	Printed-Circuit Board, PreAmp	PB1240
--			--	Printed-Circuit Board, Audio Front End, FM	PB1096-2 P966-2

If replacement parts are out of stock, locally, they may be obtained directly from the Parts Department of FISHER Radio Corporation. They will be shipped "best way", either prepaid or C.O.D. unless otherwise specified.

For instrument-operation information and technical assistance write Richard Hamilton, Customer Service Department, FISHER Radio Corporation, Long Island City, New York 11101.

TUNING METER CALIBRATION

- Connect FM generator output leads to antenna terminals.
- Set generator output to 100 mV, ± 22.5 kc deviation at 400 cps.
- Adjust meter control (on IF printed-circuit board) for tuning meter indication of 4.

MUTING CONTROL ADJUSTMENT

- Connect signal generator to the NORM antenna terminals through two 120-ohm resistors.
- Connect AC (audio) VTVM to right or left RCRDR OUTPUTS jack.
- Set generator and tuner to 98 MHz (mc).
- Modulate generator with 400 Hz (cps) to ± 22.5 kHz (kc) deviation, at 50 μ V output.
- Rotate muting-level control (R327) to its maximum counterclockwise position.
- With MUTING off, make a note of the AC (audio) VTVM reading at the RCRDR jack.
- Set MUTING selector to position 3 and adjust the muting-level control (R327) on the IF printed-circuit board for an AC (audio) VTVM reading 1 to 5 db lower than that noted previously.
- Set MUTING selector to position 2 and slowly reduce generator output to less than 30 μ V. Reading on AC (audio) VTVM should drop to approximately the same reading as that obtained in position 3. DO NOT readjust muting-level control (R327).
- Set MUTING selector to position 1 and slowly reduce generator output to less than 15 μ V. Reading on AC (audio) VTVM should drop to approximately the same reading as that obtained in position 3. DO NOT readjust muting-level control (R327).

FRONT PANEL MAINTENANCE

1. CLEANING THE DIAL GLASS

- (1) Remove the front panel. Disconnect the set from AC power as a precaution. Remove all knobs, but not the pushbuttons. Remove the three hex nuts located at the points occupied by the Volume control, the Selector switch and the Speakers switch. Then lift off the front panel.
- (2) Loosen the screws that retain the clips to the dial glass. (When you replace the dial glass, make certain to rest it by placing it firmly against the lower left-hand corner.) Swing the clips aside, and then lift off the glass.
- (3) Remove dust with a dry rag. If you wish to clean more thoroughly, use a soap and water solution only; if you use any stronger cleaning agent, you may damage the markings on the glass.

2. REPLACING DIAL LAMPS

First, disconnect the AC power cord as a precaution. Remove the front panel as described above. The lamps are held in place by spring clips and can be removed with the fingers. Replace with a new lamp from your FISHER Dealer (Part Number I-50441-1).

3. REPLACING THE DIAL POINTER LIGHT

- (1) Remove the top of the metal cabinet, after loosening the screws which fasten it in place.
- (2) Remove the front panel and dial glass as described in the paragraph above. The two wires from the dial

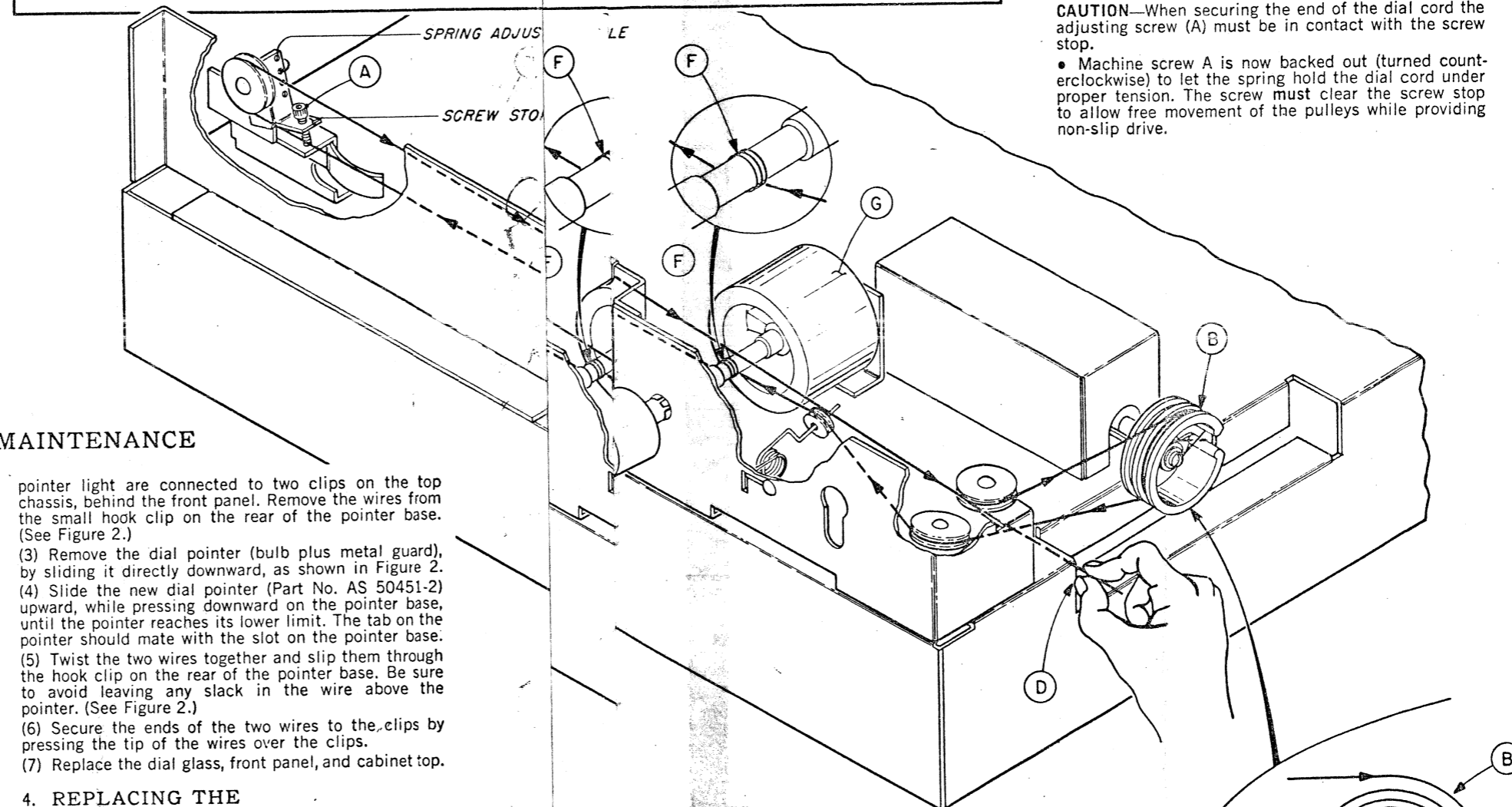
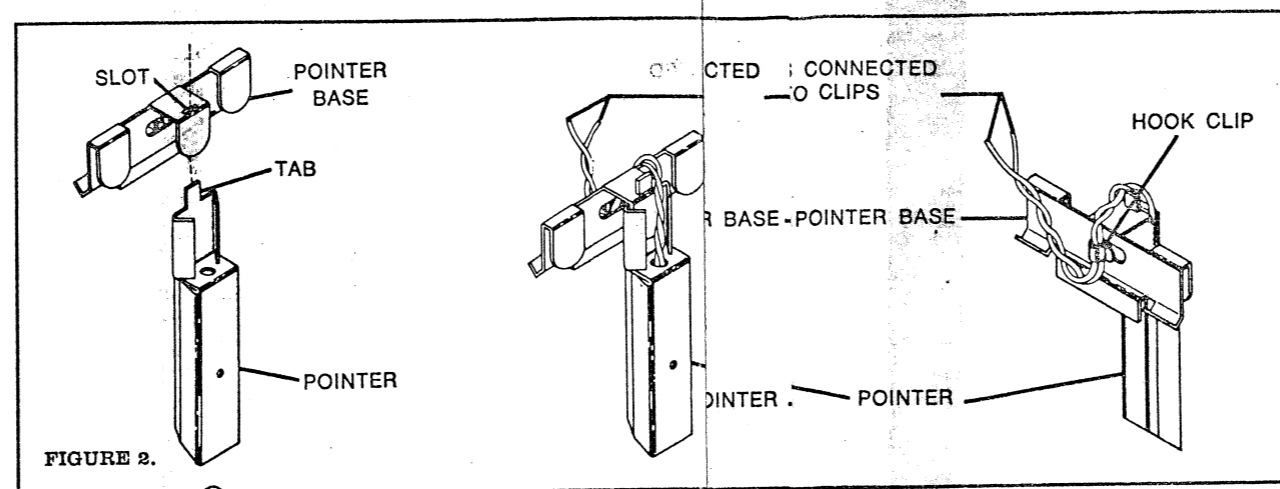

pointer light are connected to two clips on the top chassis, behind the front panel. Remove the wires from the small hook clip on the rear of the pointer base. (See Figure 2.)

- (3) Remove the dial pointer (bulb plus metal guard), by sliding it directly downward, as shown in Figure 2.
- (4) Slide the new dial pointer (Part No. AS 50451-2) upward, while pressing downward on the pointer base, until the pointer reaches its lower limit. The tab on the pointer should mate with the slot on the pointer base.
- (5) Twist the two wires together and slip them through the hook clip on the rear of the pointer base. Be sure to avoid leaving any slack in the wire above the pointer. (See Figure 2.)
- (6) Secure the ends of the two wires to the clips by pressing the tip of the wires over the clips.
- (7) Replace the dial glass, front panel, and cabinet top.

4. REPLACING THE STEREO BEACON LIGHT

- (1) Remove the top of the metal cabinet, after loosening the screws which hold it in place.
- (2) Remove the two wires of the STEREO BEACON lamp from the two clips located atop the chassis, behind the front panel.
- (3) Remove the bulb (Part No. I50594-1) from the cylinder which houses the STEREO BEACON jewel, and replace it with a new bulb.
- (4) Fit the ends of the two wires from the lamp over the clips.
- (5) Replace the cabinet top.

DIAL STRINGING

- Turn tension-relief screw A to maximum clockwise position. With screw A set to its maximum-IN position the dial cord can be pulled as tightly as possible (just before securing the loose end) without stretching the tension spring. This is not an adjustment screw. It is used only for easier dial-cord stringing.
- Rotate tuning-capacitor-drive drum B to its maximum clockwise position, as shown.
- Tie dial cord to ear C (in capacitor-drive drum) as shown in Figure 1. Dial cord goes through slot in drum and is set in the inner groove.
- Thread dial cord around pulleys (as shown) to point D.
- While holding dial cord taut with left hand, rotate the tuning-capacitor-drive drum to its maximum counterclockwise position with the right hand.
- Wrap the end of the dial cord around the body of the machine screw (E) in the hub of the drive drum and tighten. The cord goes under the flat washer.

CAUTION—When securing the end of the dial cord the adjusting screw (A) must be in contact with the screw stop.

- Machine screw A is now backed out (turned counterclockwise) to let the spring hold the dial cord under proper tension. The screw must clear the screw stop to allow free movement of the pulleys while providing non-slip drive.

ADJUSTMENTS

of dial dippage of dial cord wrapped around drive shaft need for indicates need for increased tension — move tension higher locig to a higher locating hole.

(G) doe flywheel (G) does not rotate freely and smoothly, to a lowe spring to a lower adjusting hole.

pulleys E: Nylon pulleys generally do not need lubrication. or noiseughness or noise occurs during tuning, silicone or mperatur high-temperature grease may be applied to mov- cumulatparts. Accumulations of dust should be removed lubricante any lubricant is applied. Often cleaning will need foinate the need for lubrication.

1NS230

FIGURE 1.

AMPLIFIER SECTION • MAIN CHASSIS SCHEMATIC

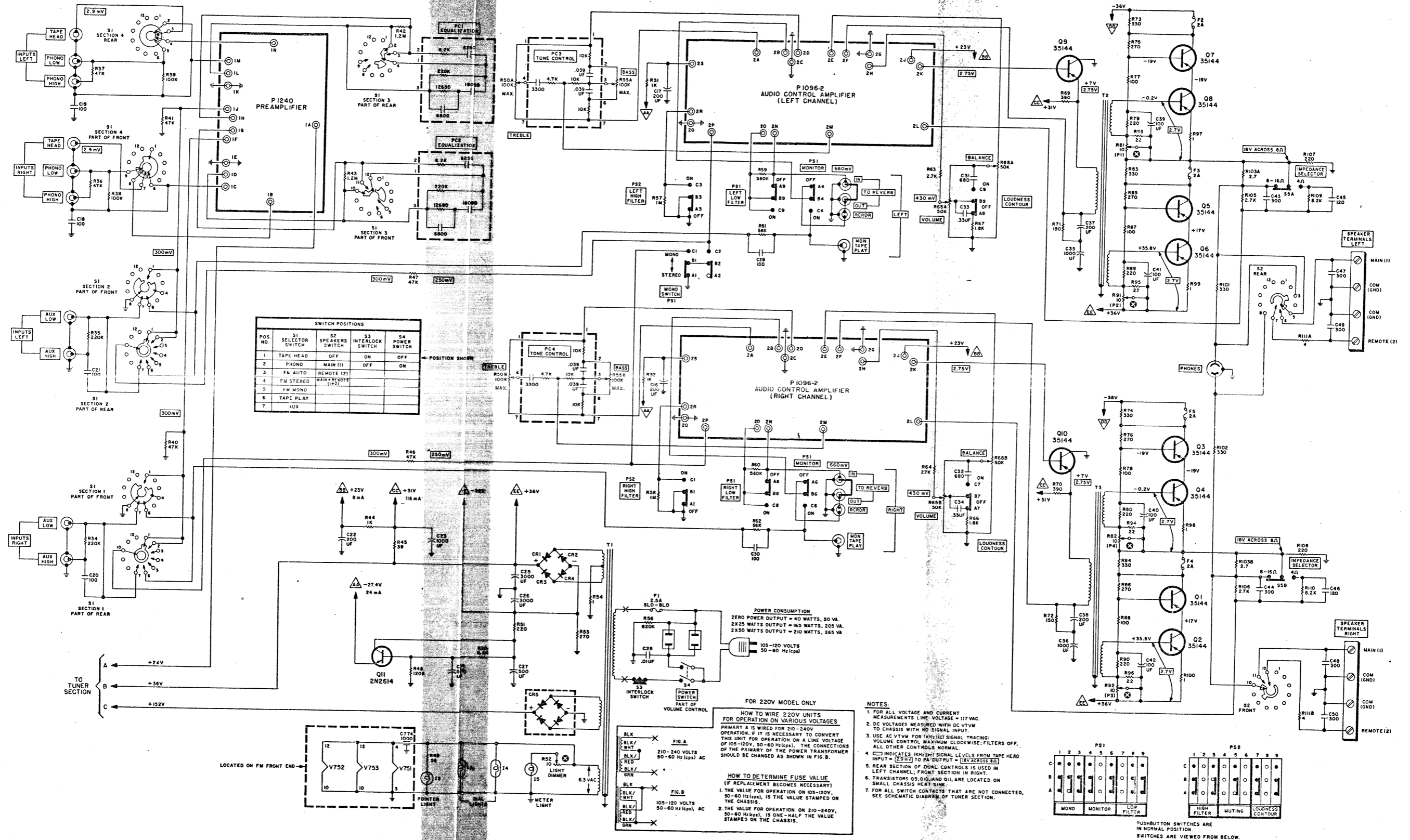

POS. NO.	S1 SELECTOR SWITCH	S2 SPEAKERS SWITCH	S3 INTERLOCK SWITCH	S4 POWER SWITCH
1	TAPE HEAD	OFF	ON	OFF
2	PHONO MAIN (I)	ON	OFF	ON
3	FM AUTO	REMOTE (I)		
4	FM STEREO	MAIN-REMOTE (I+2)		
5	FM MONO			
6	TAPE PLAY			
7	AUX			

POWER CONSUMPTION
 ZERO POWER OUTPUT = 40 WATTS, 50 VA.
 2X25 WATTS OUTPUT = 165 WATTS, 205 VA.
 2X50 WATTS OUTPUT = 210 WATTS, 265 VA.

FOR 220V MODEL ONLY
HOW TO WIRE 220V UNITS FOR OPERATION ON VARIOUS VOLTAGES
 PRIMARY A IS WIRED FOR 210-240V OPERATION. IF IT IS NECESSARY TO CONVERT THIS UNIT FOR OPERATION ON A LINE VOLTAGE OF 105-120V, 50-60 Hz (cps), THE CONNECTIONS OF THE PRIMARY OF THE POWER TRANSFORMER SHOULD BE CHANGED AS SHOWN IN FIG. B.

HOW TO DETERMINE FUSE VALUE (IF REPLACEMENT BECOMES NECESSARY)
 1. THE VALUE FOR OPERATION ON 105-120V, 50-60 Hz (cps), IS ONE-HALF THE VALUE STAMPED ON THE CHASSIS.
 2. THE VALUE FOR OPERATION ON 210-240V, 50-60 Hz (cps), IS ONE-HALF THE VALUE STAMPED ON THE CHASSIS.

- NOTES:**
- FOR ALL VOLTAGE AND CURRENT MEASUREMENTS LINE VOLTAGE = 117 VAC.
 - DC VOLTAGES MEASURED WITH DC VTVM TO CHASSIS WITH NO SIGNAL INPUT.
 - USE AC VTVM FOR IMPEDANCE SIGNAL TRACING; VOLUME CONTROL MAXIMUM CLOCKWISE; FILTERS OFF, ALL OTHER CONTROLS NORMAL.
 - INDICATES INPUT SIGNAL LEVELS FROM TAPE HEAD INPUT = (2.9mV) TO PA OUTPUT = (15V ACROSS 8Ω).
 - REAR SECTION OF DUAL CONTROLS IS USED IN LEFT CHANNEL; FRONT SECTION IN RIGHT.
 - TRANSISTORS Q1, Q2, Q3, Q4, Q5, Q6, Q7, Q8, Q9, Q10 ARE LOCATED ON SMALL CHASSIS HEAT-SINK.
 - FOR ALL SWITCH CONTACTS THAT ARE NOT CONNECTED, SEE SCHEMATIC DIAGRAM OF TUNER SECTION.

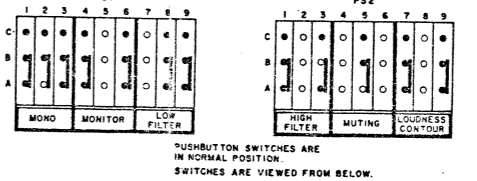

TUNER SECTION • MAIN CHASSIS SCHEMATIC

*NOTE: See MULTIPLEX DECODER alignment to determine LEFT- and RIGHT-channel outputs at terminals 4H and 4K

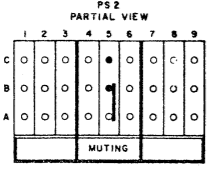
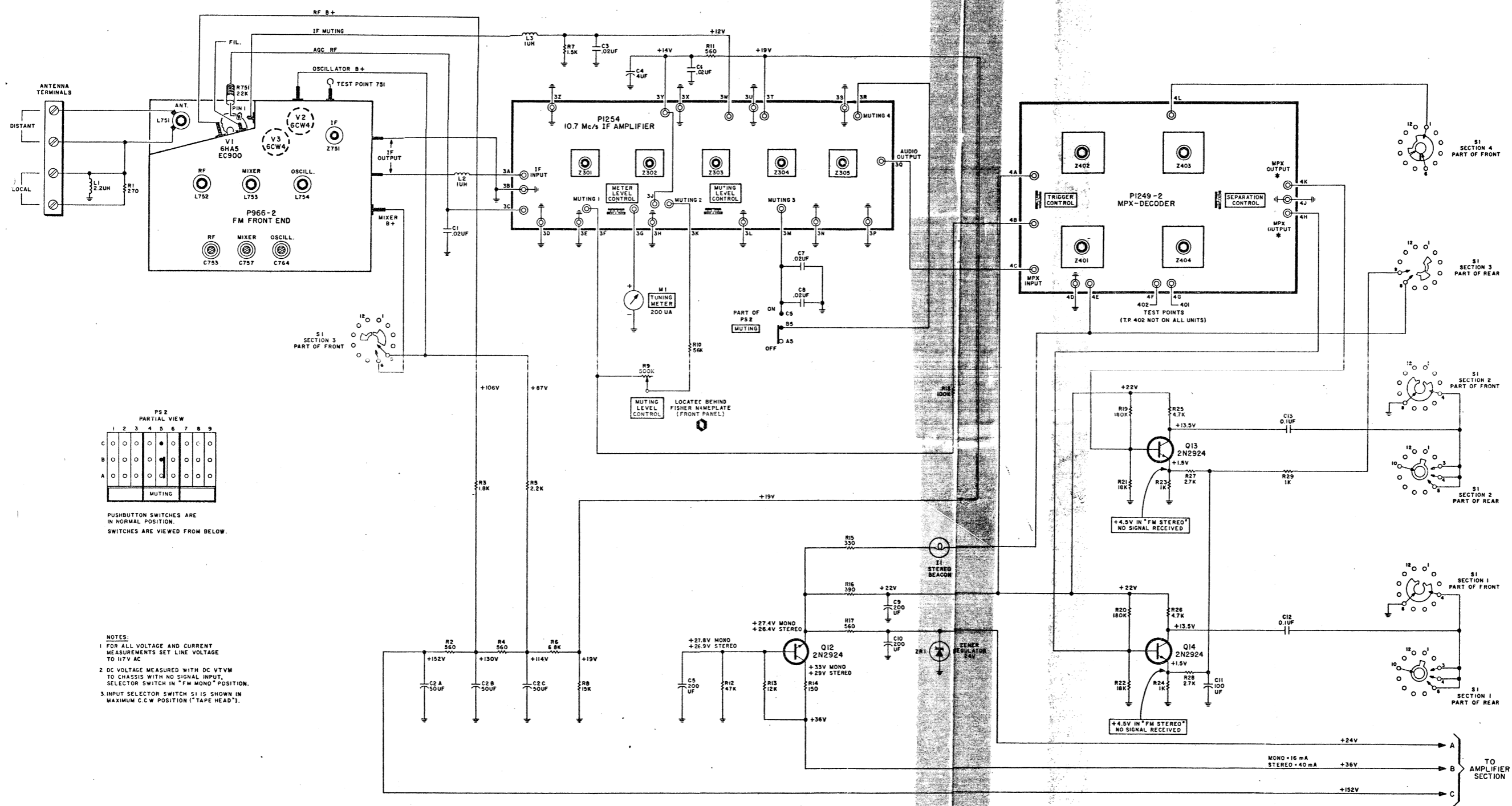

PUSHBUTTON SWITCHES ARE IN NORMAL POSITION. SWITCHES ARE VIEWED FROM BELOW.

- NOTES:
- FOR ALL VOLTAGE AND CURRENT MEASUREMENTS SET LINE VOLTAGE TO 117 V AC
 - DC VOLTAGE MEASURED WITH DC VTVM TO CHASSIS WITH NO SIGNAL INPUT. SELECTOR SWITCH IN "FM MONO" POSITION.
 - INPUT SELECTOR SWITCH S1 IS SHOWN IN MAXIMUM C.C.W POSITION ("TAPE HEAD").

AW 2385

1249-2 MULTIPLEX DECODER • SCHEMATIC

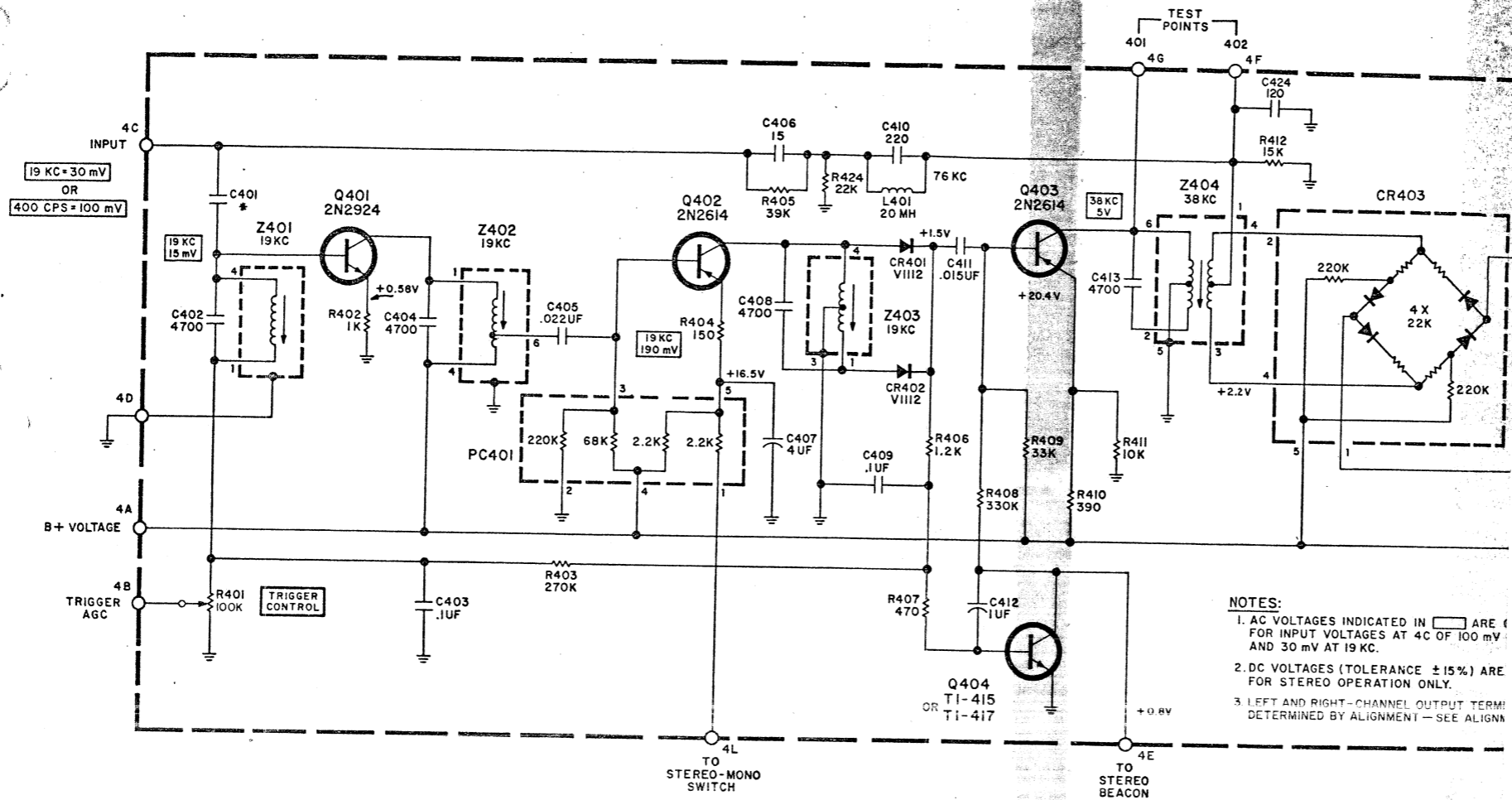

NOTES:
 1. AC VOLTAGES INDICATED IN ARE FOR INPUT VOLTAGES AT 4C OF 100 mV AND 30 mV AT 19 KC.
 2. DC VOLTAGES (TOLERANCE ±15%) ARE FOR STEREO OPERATION ONLY.
 3. LEFT AND RIGHT-CHANNEL OUTPUT TERMINALS DETERMINED BY ALIGNMENT—SEE ALIGNMENT PROCEDURE.

1249-2-H

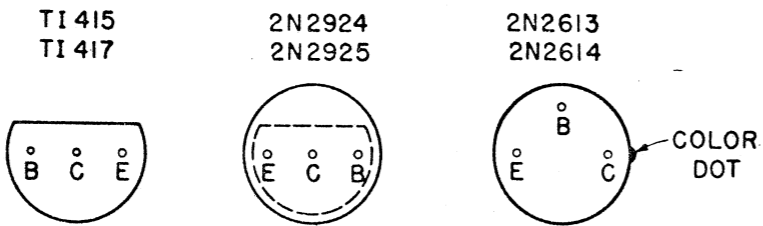

PARTS DESCRIPTION

C422, 423 Electrolytic, 4uF, 35V
 C424 Polystyrene, 120, 5%, 33V
 †Used on PB1249-1 Board—(Tube-type IF Amplifier)
 *Used on PB1249-2 Board—(Transistor-type IF Amplifier)
 **For export models only.

RESISTORS AND POTENTIOMETERS

Deposited Carbon, in ohms, 5% tolerance, unless otherwise noted. K=Kilohms, M=Megohms

Symbol	Description
R401	Pot., Trimmer, 100K, ±30%
R402	Composition, 1K, 10%, 1/2 W
R403	270K
R404	150
R405	39K
R406	1.2K
R407	470
R408	330K
R409	33K
R410	390
R411	10K
R412	15K
R413, 414	470K

CAPACITORS
 10% tolerance for all fixed capacitors, unless otherwise noted or marked GMV (guaranteed minimum value). All capacitors not marked uF are pF (uF).

Symbol	Description	Part No.
C401	†Ceramic, 68, 5%, N220	C50568-5
	*Ceramic, 220, 5%, N1500	C50568-6
C402	Mica, Silver, 4700, 5%, 100VDC	C50571-2
C403	Mylar, 0.1uF, 20%, 250V	C50635-1
C404	Polystyrene, 4700, 5%, 33V	C50636-23
C405	Mylar, .022uF, 100V	C50574-7
C406	Ceramic, 15, P100, 1000V	C50568-14
C407	Electrolytic, 4uF, 35V	C50483-1
C408	Polystyrene, 4700, 5%, 33V	C50636-23
C409	Mylar, 0.1uF, 20%, 250V	C50635-1
C410	Polystyrene, 220, 5%, 33V	C50636-3
C411	Mylar, .015uF, 100V	C50574-2
C412	Electrolytic, 1uF, 70V	C50483-16
C413	Polystyrene, 4700, 5%, 33V	C50636-23
C414, 415	Polystyrene, 330, 5%, 33V	C50636-4
C416, 417	Mylar, .01uF, 5%, 100V	C50574-1
	**Polystyrene, 6800pF, 5%, 33V	C50636-25
C418, 419	Polystyrene, 910, 5%, 33V	C50636-6
C420, 421	Mylar, .01uF, 5%, 100V	C50574-1
	**Polystyrene, 6800pF, 5%, 33V	C50636-25

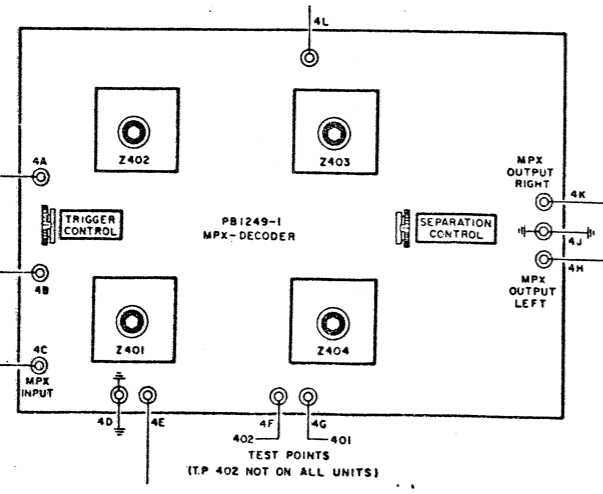

IMPROVED ALIGNMENT INSTRUCTIONS

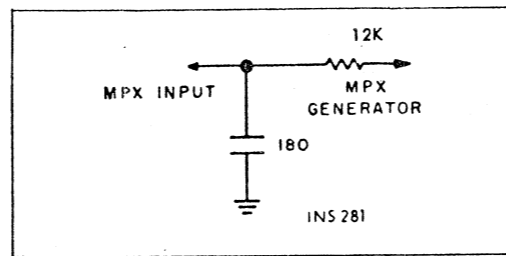
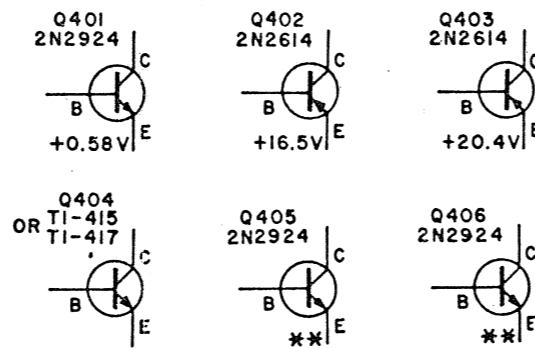
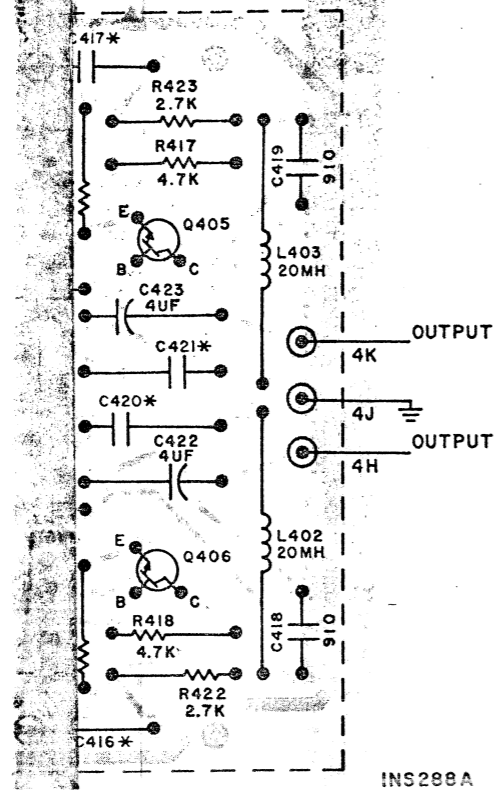

FIGURE 1. Multiplex-alignment pass filter circuit.

ALTERNATE ALIGNMENT INSTRUCTIONS

(For multiplex generators without an RF output)

Disconnect the ratio detector from the multiplex unit before using this procedure. A low-pass filter (Figure 1) is used between the MPX generator output and the input to the multiplex circuitry. It has about the same loading effect as the output of the ratio detector in the tuner.

VOLTAGE FOR P1249-1 IS +0.8V
P1249-2 IS +0.35V

OF MULTIPLEX GENERATOR CONNECTED TO INPUT OF MPX DECODER THROUGH LOW-PASS FILTER

OPERATION	LEVEL (RMS)	INDICATOR TYPE AND CONNECTION	ALIGNMENT	
			ADJUST	INDICATION
	100mV	Audio (AC) VTVM input to TP402 with a 10 pF capacitor in series with lead.	—	Read minimum AC voltage between 70 and 76 kc.
only	50mV	AC VTVM to TP401	Z401, 402, 403 and 404	Maximum AC voltage (38 kc)
MPX signal channel only	300mV	CAUTION: Some 1-kc signal will be present at both the 4H and the 4K output terminals. The terminal with the highest output signal is now the proper LEFT-channel output terminal. Leave the VTVM and scope probes connected to this point and complete alignment procedure. If it is necessary to adjust Z402 more than a half turn repeat alignment steps above.		
		Audio (AC) VTVM and oscilloscope vertical input to left channel output lug	Z402	Maximum AC voltage with clean 1 kc sine wave on oscilloscope
MPX signal channel only	300mV	Same as Step 3	MPX Separation Control	Minimum reading on Audio (AC) VTVM—should be at least 35db below reading obtained in Step 3.
4	300mV	Audio (AC) VTVM and oscilloscope vertical input to right channel output lug	—	Same Audio (AC) VTVM reading as obtained in Step 3 (± 2 db); clean 1kc sine wave on scope.
3	300mV	Same as Step 5	—	Minimum reading on Audio (AC) VTVM should be at least 35db below reading obtained in Step 5.
4	300mV	Same as Step 5		Check signal at output or recorder jacks and reverse leads going to terminals 4H and 4K for correct channel-signal output.

1-2/A FS-1209-2-H

1249-2 MULTIPLEX DECODER • PRINTED CIRCUIT LAYOUT

MULTIPLEX DECODER TESTS

- Modulate FM generator with 19 kc, ± 6.5 kc deviation. (Use external modulation if necessary.)
- Connect the FM generator output to the antenna terminals of the unit under test.
- With the FM generator set for an output of 25 μ V at the antenna terminals the stereo indicator should light up. If the generator output is reduced to 5 μ V, at the antenna terminals, the indicator light should remain ON.
- Reduce FM generator output to zero and the indicator light should go OFF.
- If the stereo indicator light does not respond properly to the tests above, readjust the trigger control (R401) until the stereo indicator lamp just turns ON with a 4 μ V signal applied to the antenna terminals.

PREFERRED ALIGNMENT INSTRUCTIONS

(Using multiplex generator with RF and 19 kc outputs and with 1 kc modulation)

In Table 1, below, a multiplex generator with an RF output is used. This is the better method of alignment since the multiplex circuitry is connected to the tuner with which it will be used. Check the alignment of the IF stages before making multiplex adjustments. Poor IF alignment can make proper multiplex operation impossible.

This table is based on the FISHER Model 300 multiplex generator. Another alignment procedure, for MPX generators without an RF output, is shown in Table 2.

TEST EQUIPMENT: Multiplex Generator, Audio (AC) Vacuum-Tube Voltmeter (RMS type preferred), Vacuum-Tube Voltmeter (DC VTVM), Oscilloscope (100 kc minimum) with external sweep input.

WARNING: Use only the proper alignment tool to prevent core breakage.

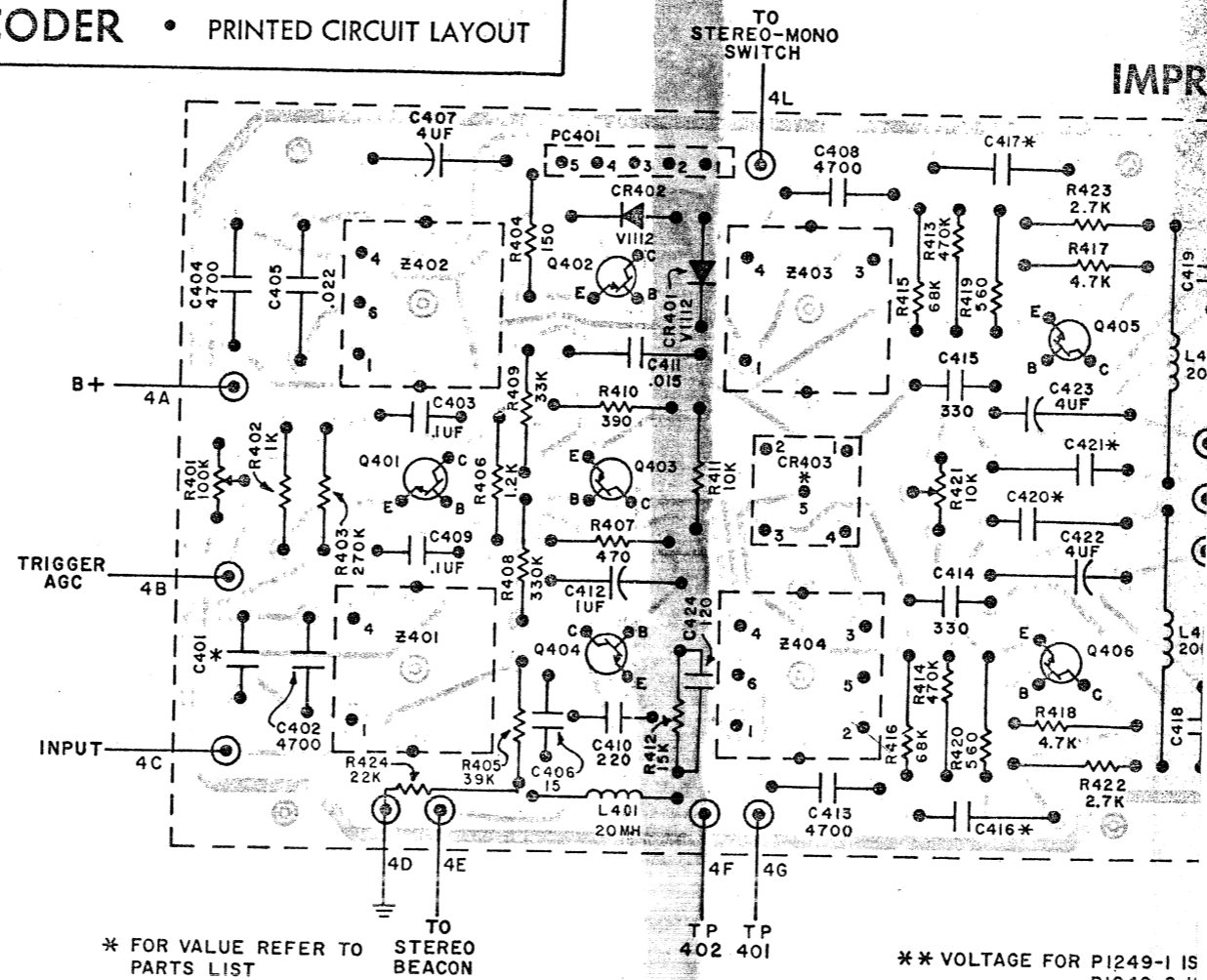

MULTIPLEX-GENERATOR RF OUTPUT CONNECTED TO ANTENNA TERMINALS

STEP	GENERATOR MODULATION	RF DEV.	INDICATOR TYPE AND CONNECTION	ALIGNMENT	
				ADJUST	INDICATION
1	70 to 76 kc (connect external audio generator to SCA input of multiplex generator.)	± 25 kc	Audio (AC) VTVM input to TP402 with a 10 pF capacitor in series with lead.	--	Read minimum AC voltage between 70 and 76 kc.
2	19 kc pilot only	± 6.5	AC VTVM to TP401	Z401, 402, 403 and 404	Maximum AC voltage (38 kc)
3	Composite MPX signal 1 kc on left channel only	± 75 kc	CAUTION: Some 1-kc signal will be present at both the 4H and the 4K output terminals. The terminal with the highest output signal is now the proper LEFT-channel output terminal. Leave the VTVM and scope probes connected to this point and complete alignment procedure. If it is necessary to adjust Z402 more than a half turn repeat alignment steps above.		
				Audio (AC) VTVM and oscilloscope vertical input to left channel output lug	Z402
4	Composite MPX signal 1 kc on right channel only	± 75 kc	Same as Step 3	MPX Separation Control (R421)	Minimum reading on Audio (AC) VTVM--should be at least 35db below reading obtained in Step 3.
5	Same as Step 4	± 75 kc	Audio (AC) VTVM and oscilloscope vertical input to right channel output lug	--	Same Audio (AC) VTVM reading as obtained in Step 3 (± 2 db); clean 1kc sine wave on scope.
6	Same as Step 3	± 75 kc	Same as Step 5		Minimum reading on Audio (AC) VTVM should be at least 35db below reading in Step 5.
7	Same as Step 4	± 75 kc	Same as Step 5		Check signal at output or recorder jacks and reverse leads going to terminals 4H and 4K for correct channel-signal output.

COMPOSITE OUTPUT OF MULTIPLEX GENERATOR

STEP	GENERATOR MODULATION	LEVEL (RMS)
1	70 to 76 kc.	100mV
2	19 kc pilot only	50mV
3	Composite MPX signal 1 kc on left channel only	300mV
4	Composite MPX signal 1 kc on right channel only	300mV
5	Same as Step 4	300mV
6	Same as Step 3	300mV
7	Same as Step 4	300mV

1096 AMPLIFIER • SCHEMATIC

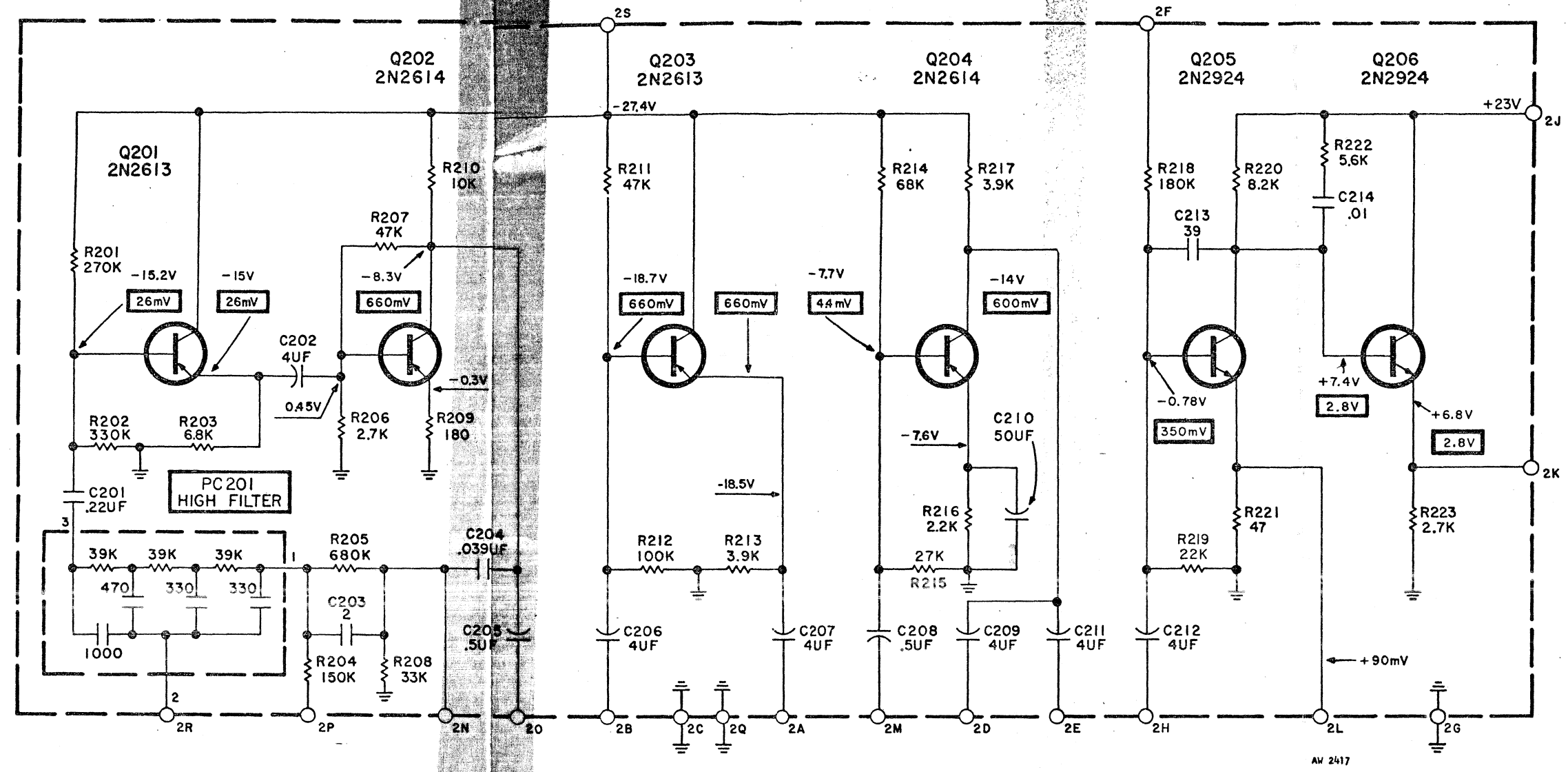

AW 2417

PARTS DESCRIPTION LIST

CAPACITORS			RESISTORS			MISCELLANEOUS		
Symbol	Description	Part No.	Symbol	Description	Part No.	Symbol	Description	Part No.
C201	Mylar, .22uF, 10%, 250V	C50B575-2	R207	47K	R12DC473J	PC201	Printed Circuit, High Filter	PC50B187-13
C202	Electrolytic, 4uF, 35V	C50483-1	R208	33K	R12DC333J	Q201, 203	Transistor, 2N2613	TR2N2613
C203	Ceramic, 2pF ±.25pF, NPO, 1000V	C50B568-1	R209	180	R12DC181J	Q202, 204	Transistor, 2N2614	TR2N2614
C204	Mylar, .039uF, 10%, 100V	C50B574-4	R210	10K	R12DC103J	Q205, 206	Transistor, 2N2924	TR2N2924
C205	Electrolytic, .5uF, 70V	C50483-11	R211	47K	R12DC473J			
C206, 207	Electrolytic, 4uF, 35V	C50483-1	R212	100K	R12DC104J			
C208	Electrolytic, .5uF, 70V	C50483-11	R213	3.9K	R12DC392J			
C209	Electrolytic, 4uF, 35V	C50483-1	R214	68K	R12DC683J			
C210	Electrolytic, 50uF, 10V	C50483-15	R215	27K	R12DC273J			
C211, 212	Electrolytic, 4uF, 35V	C50483-1	R216	2.2K	R12DC222J			
			R217	3.9K	R12DC392J			
			R218	180K	R12DC184J			
			R219	12K	R12DC123J			
			R220	Composition, 8.2K, 5%, 1/2W	RC20BF822J			
			R221	47	R12DC470J			
			R222	5.6K	R12DC562J			
			R223	Composition, 2.7K, 10%, 1/2W	RC20BF272K			

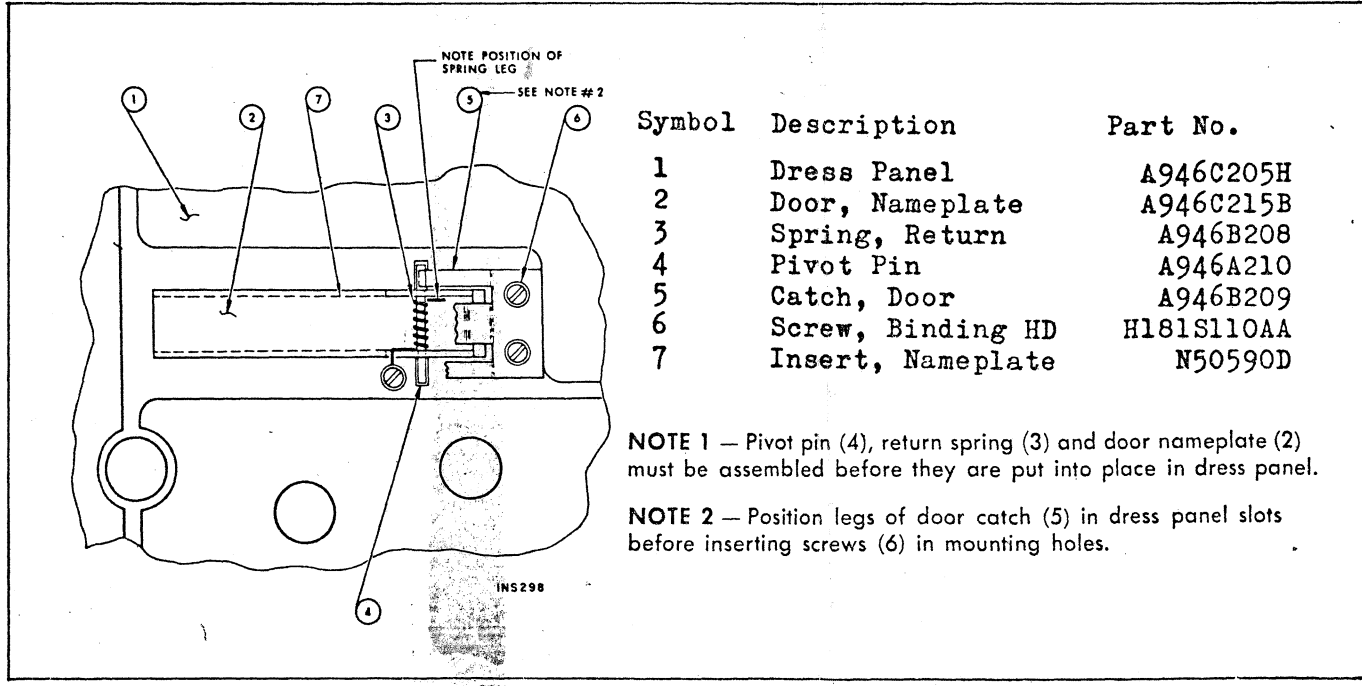

Symbol	Description	Part No.
1	Dress Panel	A946C205H
2	Door, Nameplate	A946C215B
3	Spring, Return	A946B208
4	Pivot Pin	A946A210
5	Catch, Door	A946B209
6	Screw, Binding HD	H181S110AA
7	Insert, Nameplate	N50590D

NOTE 1 — Pivot pin (4), return spring (3) and door nameplate (2) must be assembled before they are put into place in dress panel.

NOTE 2 — Position legs of door catch (5) in dress panel slots before inserting screws (6) in mounting holes.

17-9) 13-946-H

AUDIO AMPLIFIER TESTS

Control Positions for Tests

1—Unplug unit from AC-power line.

2—Set Balance, Bass and Treble controls to their center positions.

Press Monitor pushbutton in. Set Speaker selector to position 1. Hi-Filter and Low-Filter switches out. Selector switch to AUX. Mono switch in the out position. The impedance selector (on the rear apron of chassis) is to be set to the 8-16 ohms position.

Output Stage Balancing and IM Distortion Measurements

1—Connect an 8-ohm, 50-watt resistor across the left output terminals. In parallel to the load resistor connect the input leads of an IM (Inter-Modulation) distortion analyzer and the leads of a DC VTVM capable of reading 0.1 volt with accuracy.

2—Connect IM-analyzer generator output to the left Monitor input.

3—Apply AC power and rotate Volume control to its maximum clockwise position—full volume.

4—Increase signal input to amplifier for 40-watts output. (14.7 VAC across 8-ohm load resistor). After one full minute of warm-up time proceed to next step. *The warm-up time is very important (to get proper balance) — the characteristics of the transistors change slightly as their internal temperature rises. A longer warm-up time will not damage the transistors. Once they are warm the tests and adjustments should be completed without delay—before they can cool off.*

5—Reduce IM-analyzer generator output for 5 watts output from amplifier (5.16 VAC across load).

6—Adjust P1 and P2 (P3 and P4 for right channel) for minimum IM distortion and zero DC voltage across the load. (IM distortion should be less than 0.8% and DC voltage lower than ±0.1 volts across the 8-ohm load. Use two screwdrivers to adjust the controls—it's faster than shifting from one control to the other.)

7—Increase signal input for 40 watts output from amplifier. IM reading should be less than 1%—DC across load should be less than ±0.3 volt.

REPEAT steps 1 through 7 (above) for right-channel tests.

NOTE—If any of the above instructions are different from those supplied with the IM analyzer instruction manual, it is best to follow those in the manual. If a load resistor of 50-watts rating is built into the IM analyzer, a separate load resistor is not required for the channel under test—one should be wired across the other channel as a precaution. For best results the IM range switch should be set to give a reading in the center to full-scale portion of the meter scale—this gives greater accuracy.

Harmonic Distortion Test

1—Set amplifier controls to positions indicated above (control positions).

2—Connect an audio (sine-wave) generator to the left AUX input. Connect the harmonic-distortion analyzer to the left speaker #1 terminals across an 8-ohm, 50-watt resistive load.

3—Apply AC power — rotate Volume control to its maximum clockwise position.

4—Set the frequency control of the audio generator to 20 cycles. Adjust the output level for 40 watts (17.9 VAC) across the 8-ohm load. Harmonic distortion should be less than 1%.

REPEAT steps above for right-channel harmonic-distortion measurements.

Stability Test

1—Connect audio (sine-wave) generator to the left AUX input. Across the left-speaker terminals connect an 8-ohm, 50-watt load resistor and the vertical-input leads of an oscilloscope.

2—Set amplifier controls to positions listed above (control positions).

1096 AMPLIFIER • PRINTED CIRCUIT LAYOUT

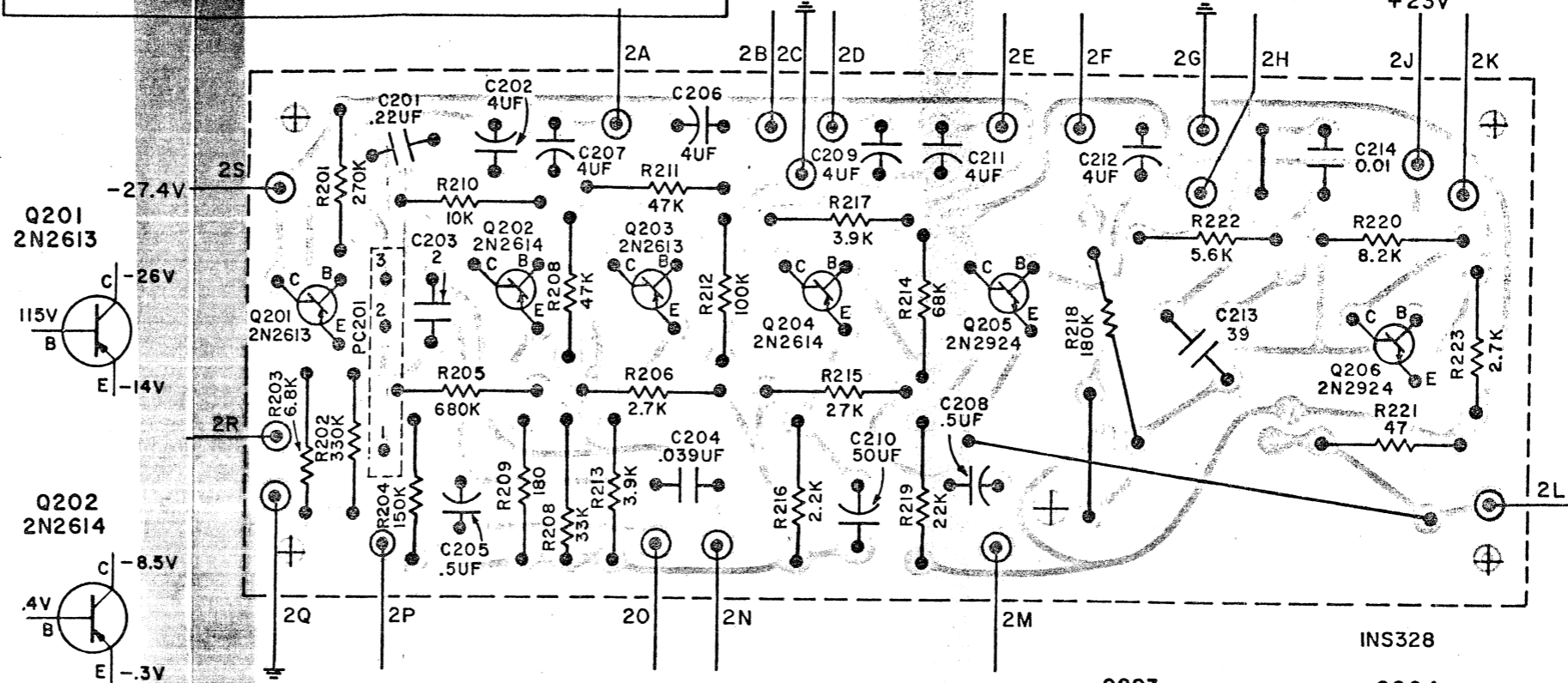

3—Apply AC power—rotate Volume control to its maximum clockwise position—full volume.

4—Set the frequency control of the audio generator to 20 cycles. Increase the output level of the audio generator until the sine waves, as viewed on the scope, start to distort—the peaks are clipped from overdriving the amplifier. Check waveforms on scope for instability—changes in wave shape or oscillation (thicker line at a portion of the waveform).

5—Repeat the above steps using a 0.1-uf capacitor as a load. Remove the 8-ohm resistor.

REPEAT steps 1 through 5, above, for the right stereo channel.

Transistor Testing

If a power-transistor tester is not available the circuit in Figure can be used to determine the DC beta of the transistors. This is not a complete test of the transistor.

OPERATION: Connect the transistor to the test circuit. Adjust R2 for a 0.5 ampere reading on M2 in the collector circuit. The DC beta is then calculated by:

$$\text{DC beta} = \frac{\text{reading of M2}}{\text{reading of M1}}$$

The DC beta should be between 50 and 250.

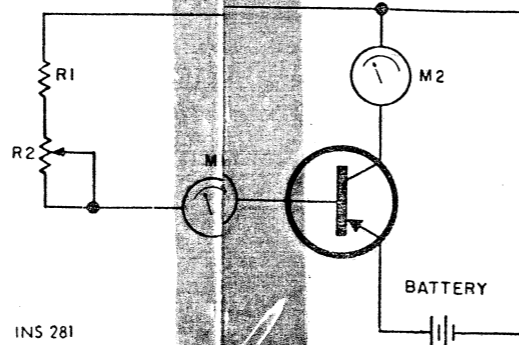

Voltage tests can be made with safety — without ruining transistors — by substituting resistors for the emitter-collector circuit of the power transistors. Voltages and resistor values are given

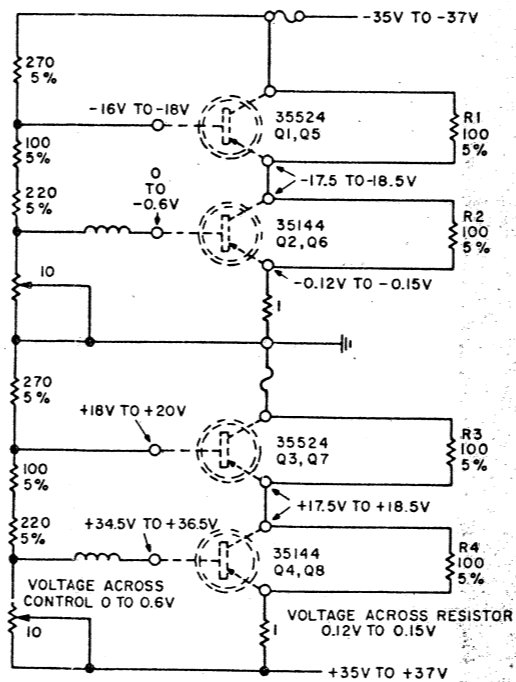

NOTES:
1. VALUES MEASURED WITH DCVTVM TO GROUND, UNLESS OTHERWISE SPECIFIED.

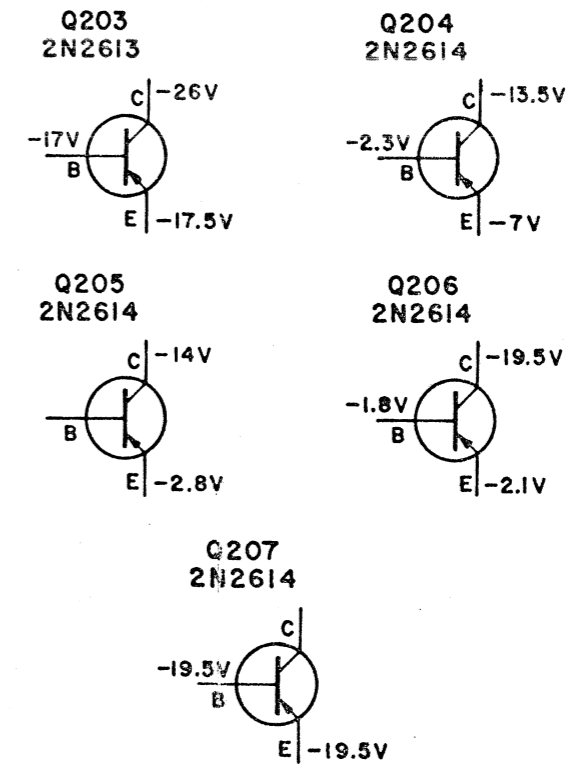

Output Stage and Driver—Replacements for output and driver transistors, if necessary, must be made from the same beta group as the original type. The beta group is indicated by a colored dot on the mounting flange of the transistor. Be sure to include this information, when ordering replacement transistors.

(8-9) FS-946-G-11

P1254 IF AMPLIFIER

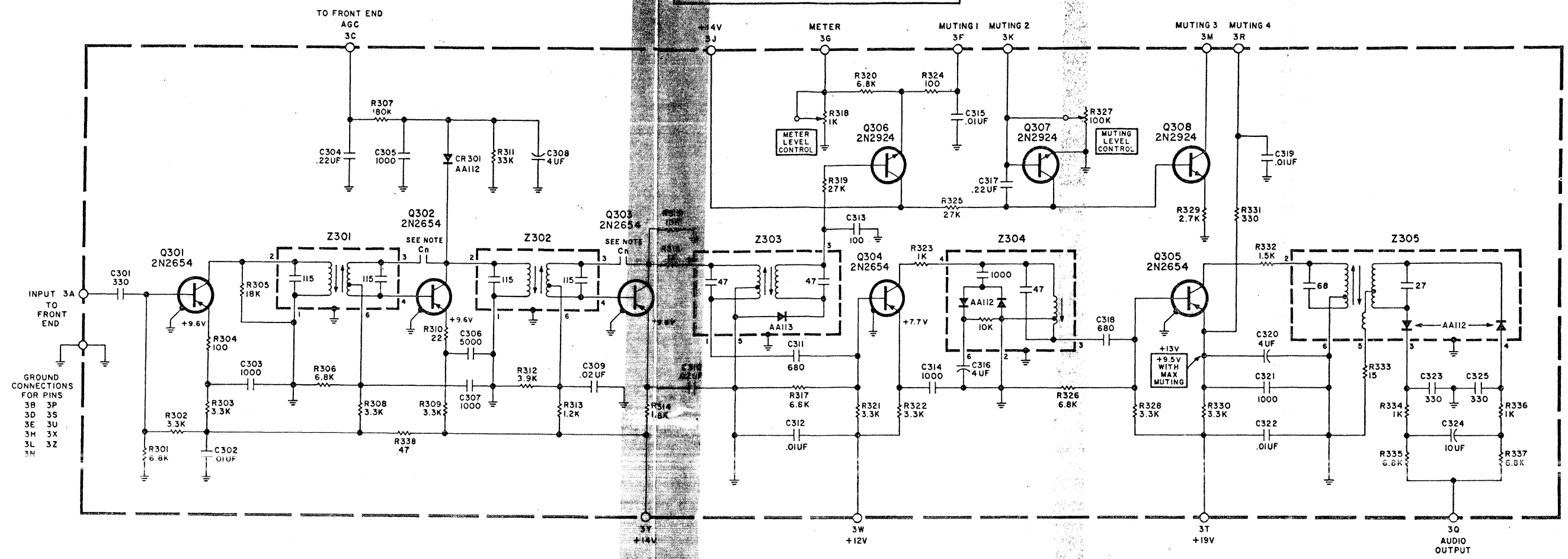

NOTE:
CAPACITORS LABELLED Cn
CONSIST OF 2 PARALLEL STRIPS
ON THE PRINTED CIRCUIT BOARD.

P1254
AW#2354D

PARTS DESCRIPTION LIST

2N2924
2N2925

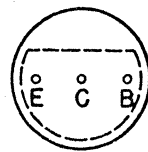

2N2654

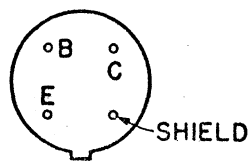

INS 305

CAPACITORS

Symbol	Description	Part No.
C301	Ceramic, 330pF, 10% 1000V	C50569-1
C302	Ceramic, .01uF +80-20%, 1000V	C50570-1
C303	Ceramic, 1000pF, 20%, 1000V	C50569-4
C304	Mylar .22uF, 10%, 160V	C50575-2
C305	Ceramic, 1000pF, 20%, 1000V	C50569-4
C306	Ceramic, 5000pF, 20%, 500V	C50567-2
C307	Ceramic, 1000pF, 20%, 1000V	C50569-4
C308	Electrolytic, 4uF, 35V	C50483-1
C309	Ceramic, .02uF +80-20%, 100V	C50073-1
C310	Ceramic, .02uF +80-20%, 100V	C50570-2
C311	Ceramic, 680pF, 20%, 1000V	C50579-2
C312	Ceramic, .01uF, +80-20%, 1000V	C50570-1
C313	Ceramic, 100pF, 10%, N1500, 1000V	C50568-1
C314	Ceramic, 1000pF, 20%, 1000V	C50569-4
C315	Ceramic, .01uF, +80-20% 1000V	C50570-1
C316	Electrolytic, 4uF, 35V	C50583-1
C317	Mylar .22uF, 10%, 160V	C50575-2
C318	Ceramic, 680pF, 10% 1000V	C50569-2
C319	Ceramic, .01uF, +80-20%, 1000V	C50570-1
C320	Electrolytic, 4uF, 35V	C50483-1
C321	Ceramic, 1000pF, 20%, 1000V	C50569-4
C322	Ceramic, 01uF, +80-20%, 1000V	C50570-1
C323	Ceramic, 330pF, 10%, 1000V	C50569-1

C324	Electrolytic, 10uF, 35V	C50483-2
C325	Ceramic, 330pF, 10%, 1000V	C50569-1

RESISTORS AND POTENTIOMETERS

Deposited carbon in ohms, 5% tolerance,
1/8 watt unless otherwise noted.
K = Kilohms, M = Megohms.

Symbol	Description	Part No.
R301	6.8K	R12DC682J
R302, 303	3.3K	R12DC332J
R304	100	R12DC101J
R305	18K	R12DC183J
R306	6.8K	R12DC682J
R307	180K	R12DC184J
R308, 309	3.3K	R12DC332J
R310	22	R12DC220J
R311	33K	R12DC333J
R312	3.9K	R12DC392J
R313, 314	3.3K	R12DC332J
R315	10K	R12DC103J
R316	1K	R12DC102J
R317	6.8K	R12DC682J
R318	Potentiometer, 1K, 30%, Meter Level Control	R50694-3
R319	27K	R12DC273J
R320	6.8K	R12DC682J
R321, 322	3.3K	R12DC332J

R323	1K	R12DC102J
R323	100	R12DC101J
R325	27K	R12DC273J
R326	6.8K	R12DC682J
R327	Potentiometer, 100K, 30%, Muting Level Control	R50694-6
R328	3.3K	R12DC332J
R329	2.7K	R12DC272J
R330	3.3K	R12DC332J
R331	330	R12DC331J
R332	1.5K	R12DC152J
R333	15	R12DC150J
R334	1K	R12DC102J
R335	6.8K	R12DC682J
R336	1K	R12DC102J
R337	6.8K	R12DC682J
R338	47	R12DC470J

MISCELLANEOUS

Symbol	Description	Part No.
CR301	Diode A112	V50260-16
Q301, 302, 303	Transistor, 2N2654	TR2N2654
Q304, 305	Transistor, 2N2654	TR2N2654
Q306, 307, 308	Transistor, 2N2924	TR2N2924
Z301, 302	Transformer, IF	ZZ50210-46
Z303	Limiter Coil	ZZ50210-69
Z304	Limiter Coil	ZZ50210-52
Z305	Ratio Detector	ZZ50210-55

1254 IF AMPLIFIER • PRINTED CIRCUIT LAYOUT

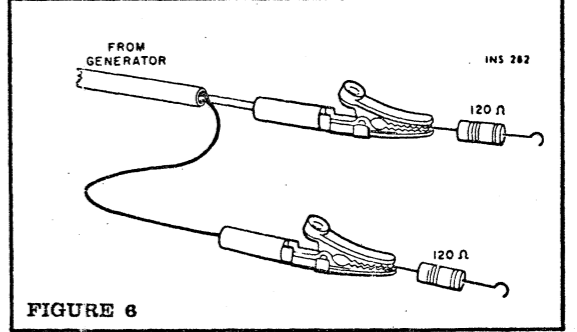
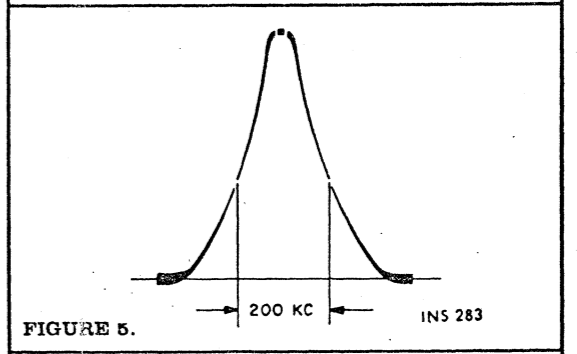
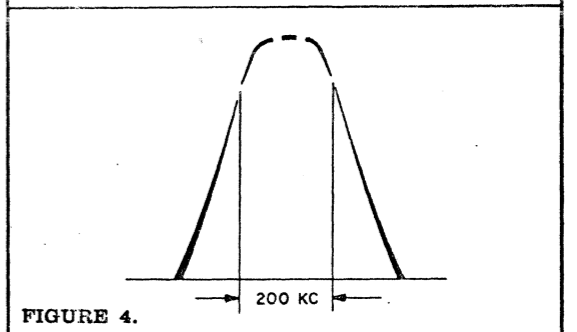
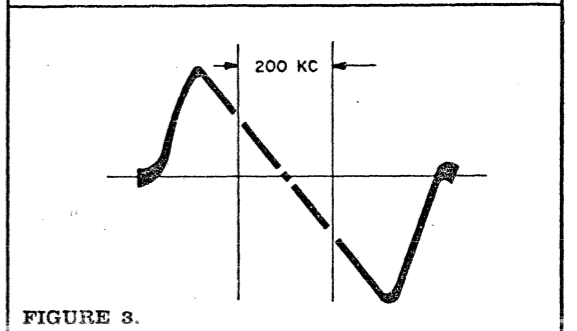
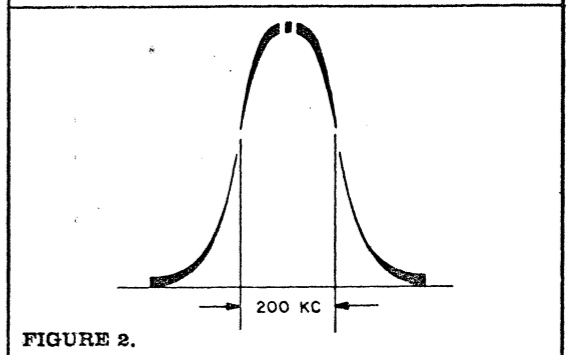
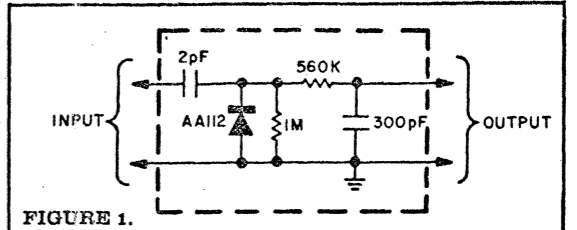
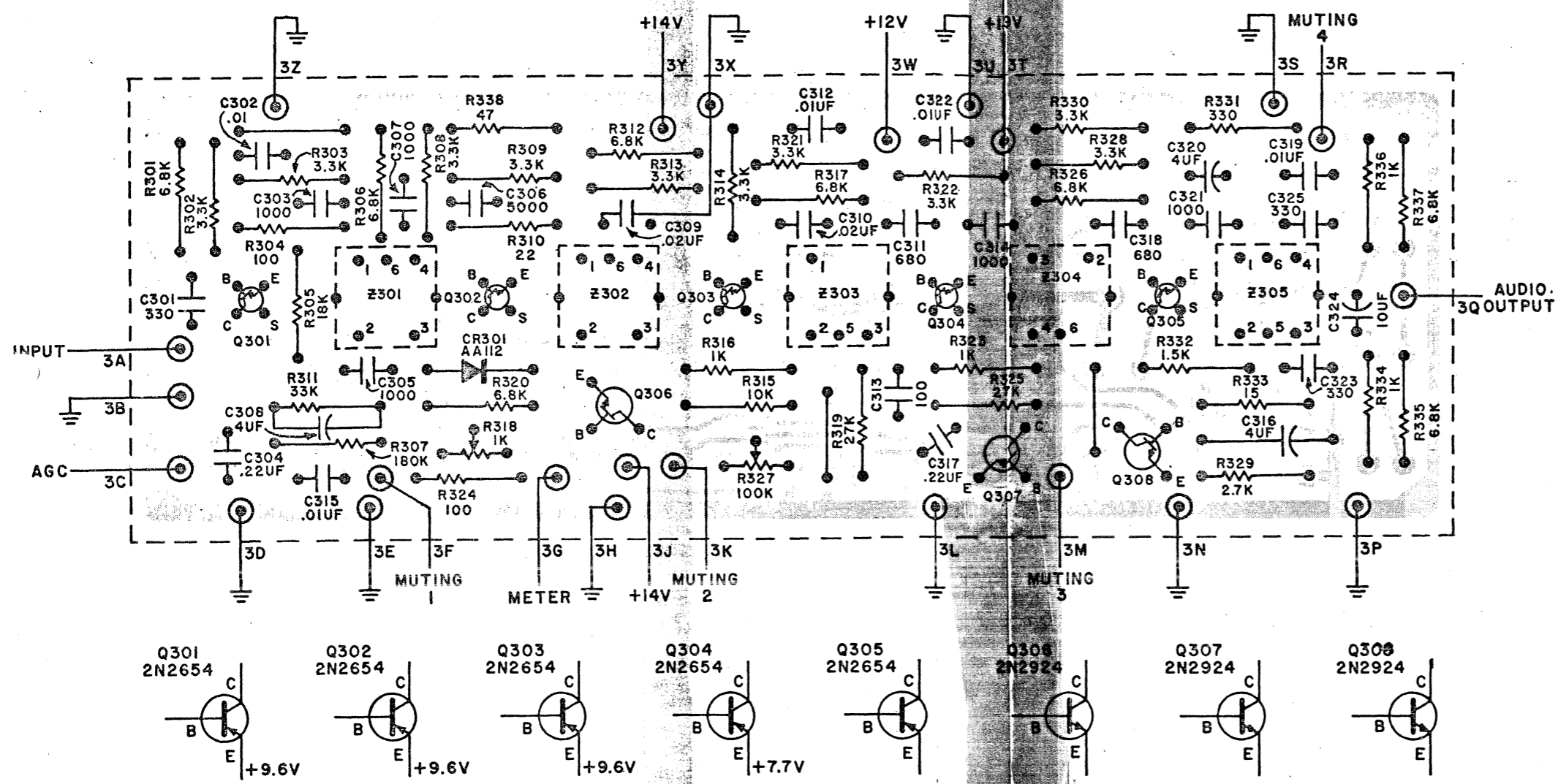

ALIGNMENT INSTRUCTIONS

IF ALIGNMENT (General Maintenance)
Set selector switch to FM MONO. MONO pushbutton depressed. HIGH FILTER, LOW FILTER and MUTING switches "OFF" (out position). VOLUME to lowest output (maximum CCW) position.

- 1—Connect sweep generator output to the insulation of wire connected to front-end TP 751. Connect scope input and DC VTVM (through diode probe—Fig. 1) to lead to collector of Q303, and ground.

NOTE: The connection between the lead of the 1K resistor and the diode probe must be as short as possible.

- 2—Adjust front-end Z751 (top and bottom) for maximum gain and a symmetrical curve (Fig. 2). Keep generator output as low as possible.
- 3—Connect scope input to the left or right RCDR output jack. Ratio detector curve should be like that in Fig. 3.

IF ALIGNMENT (After part replacement)
Use same switch positions as above.

- 1—Connect 10.7 mc generator output lead to the collector of Q303. DO NOT use AM or FM modulation.

- 2—Connect DC VTVM across C324 (ratio-detector filter). Use 100K resistor in series with each lead—DO NOT ground VTVM.
- 3—Adjust Z303, Z304 bottom cores and Z305 top and bottom cores for maximum DC VTVM reading. Re-adjust generator output during alignment to keep DC VTVM reading between 4 and 5.5 volts.
- 4—Connect DC VTVM and scope to diode probe (as in Step 1—General Maintenance alignment, above).
- 5—Connect sweep generator to point 3A of IF amplifier board. Adjust top and bottom cores of Z301 and Z302, and bottom core of Z303 for maximum gain and a symmetrical curve. (Figure 2.) Adjust generator output during alignment to keep DC VTVM reading between -0.5 and -2 volts.
- 6—Connect sweep-generator output lead to the insulation of the wire going to TP 751 (front-end). Adjust Z751 (top and bottom) for maximum gain and a symmetrical curve on scope. Generator output must be adjusted during alignment to keep DC VTVM readings between -0.5 and -1.5 volts. If response curve should now be like that in Figure 4.

7—Connect scope vertical input to point M1 on the IF-amplifier board and adjust the top core of Z303 for maximum gain and curve like that in Figure 5.

FM FRONT-END ALIGNMENT
NOTE: This step is not necessary unless the circuitry has been disturbed or components replaced.

- 1—Connect DC VTVM to point M1 on the IF board FM-signal generator (with two 120-ohm composition resistors in series with the leads) to the 300-ohm antenna terminals.
- 2—Set generator and tuner dials to 90 mc. Adjust the oscillator coil (L754) core first — then adjust RF coils (L753, L752) for maximum DC VTVM reading.
- 3—Set generator and tuner dials to 106 mc. First adjust the oscillator trimmer (C764) and then the RF trimmers (C757, C753).
- 4—Repeat steps 2 and 3 several times until calibration is accurate when VTVM reading is maximum. Use as little generator output as possible.
- 5—Set generator and tuner dials to 98 mc. Adjust antenna coil (L751) for maximum DC VTVM reading.

INS 292

(1-2/A) FS-1254-H

CHASSIS LAYOUT

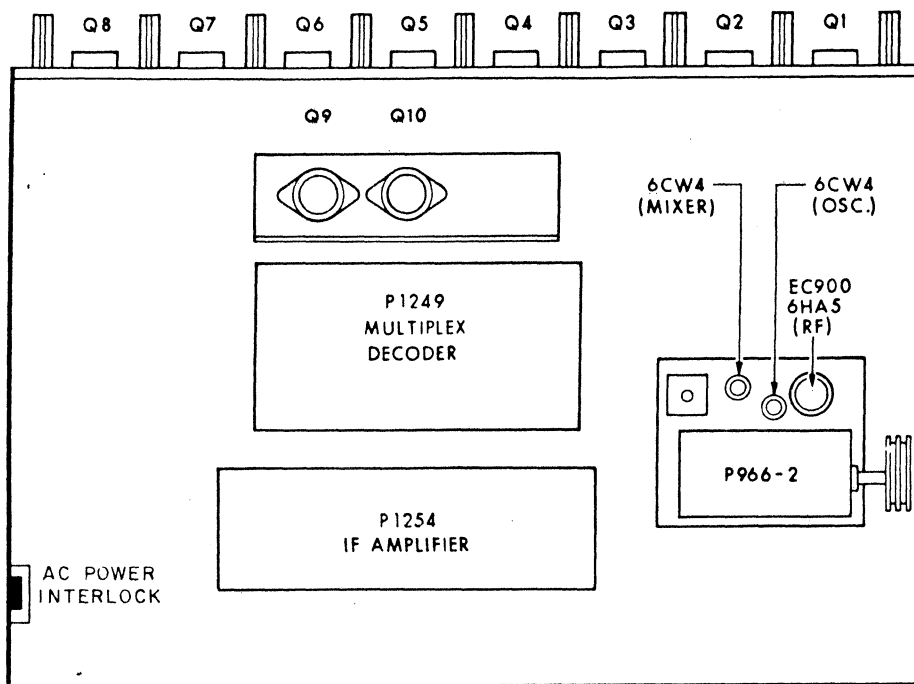

INS247A

TOP VIEW

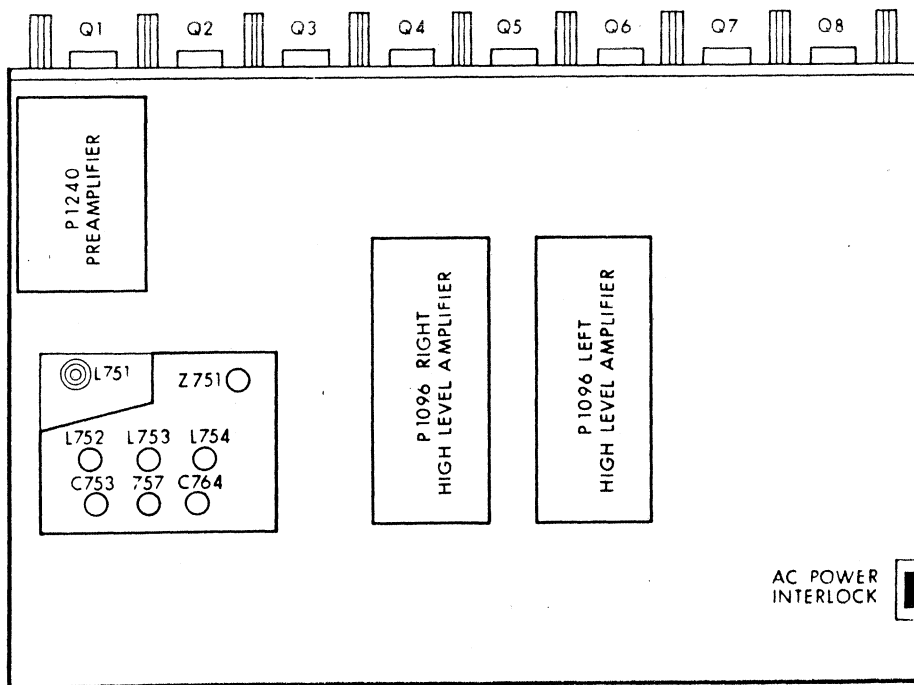

INS 248A

BOTTOM VIEW

COMPONENT CONNECTIONS

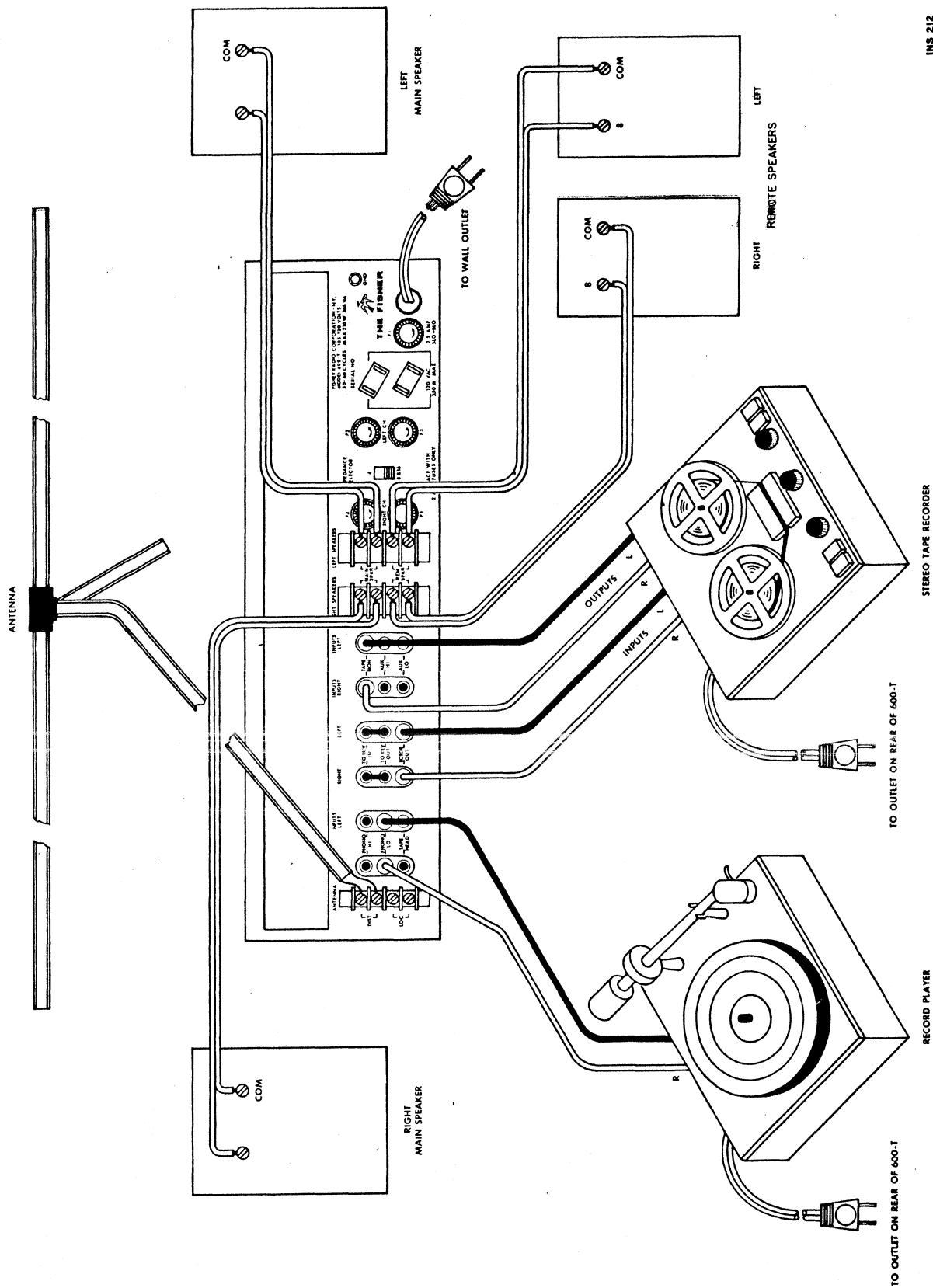

INS 212

STEREO TAPE RECORDER

TO OUTLET ON REAR OF 600-T

RECORD PLAYER

TO OUTLET ON REAR OF 600-T

(L-9) FS-946-G-R



FISHER RADIO CORPORATION • NEW YORK

N946-103BX

© COPYRIGHT 1965 FISHER RADIO CORPORATION All Rights Reserved

PRINTED U.S.A.

70M